

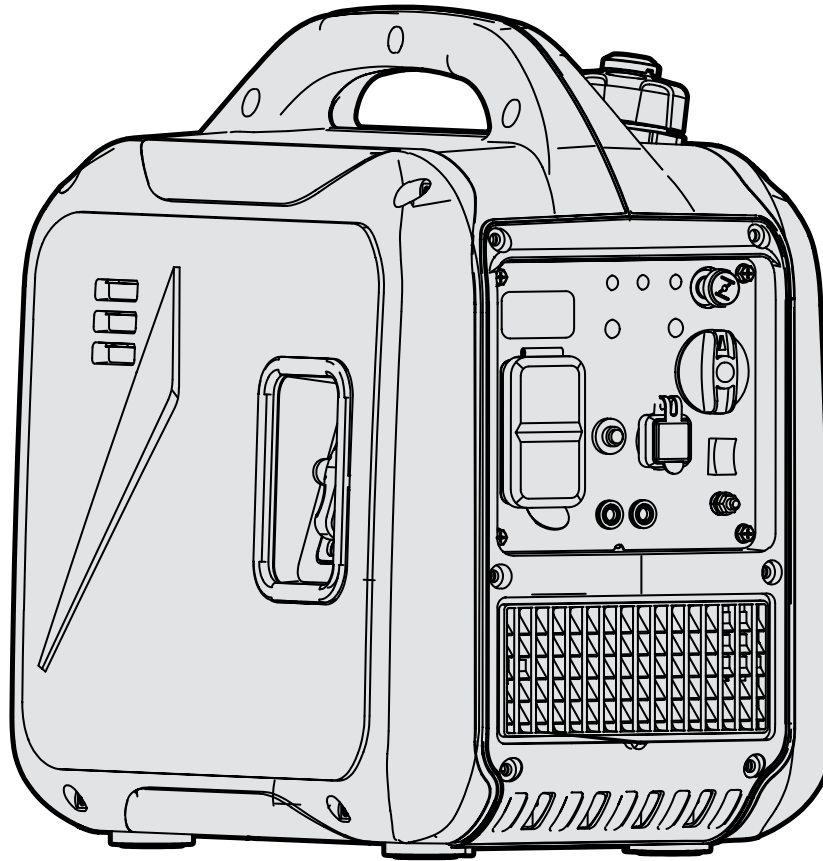

MODEL 56250i

2500W PORTABLE INVERTER GENERATOR

Instruction Manual



NEED HELP? CONTACT US!

Have product questions? Need technical support? Please feel free to contact us:



1-847-429-9263 (M-F 8AM-5PM CST)



TECHSUPPORT@WENPRODUCTS.COM

IMPORTANT: Your new tool has been engineered and manufactured to WEN's highest standards for dependability, ease of operation, and operator safety. When properly cared for, this product will supply you years of rugged, trouble-free performance. Pay close attention to the rules for safe operation, warnings, and cautions. If you use your tool properly and for its intended purpose, you will enjoy years of safe, reliable service.

For replacement parts and the most up-to-date instruction manuals, visit ***WENPRODUCTS.COM***

CONTENTS

WELCOME	3
Specifications.....	3
Introduction	4
SAFETY	5
Safety Information	5
Generator Safety Warnings	6
BEFORE OPERATING	9
Unpacking & Packing List.....	9
Know Your Inverter Generator.....	10
Generator Preparation.....	12
OPERATION & MAINTENANCE	16
Starting Your Generator	16
Using Your Generator.....	18
Shutting Off Your Generator.....	23
Maintenance.....	24
Transportation & Storage.....	31
Troubleshooting Guide.....	32
Wiring Diagram.....	33
Exploded View & Parts List.....	34
Warranty Statement	41

To purchase accessories for your tool, visit ***WENPRODUCTS.COM***

Parallel Connection Kit

Magnetic Oil Dipstick (Model Number 55201)

Universal Weatherproof Inverter Generator Cover (Model 56200iC)

SPECIFICATIONS

GENERATOR

Rated Wattage	1900W
Surge Wattage	2500W
Rated Voltage	AC: 120V
	DC: 5V
Rated Amperage	AC: 15.8A
	DC: 2.1A
Phase	Single
Frequency	60Hz
Decibel Rating	65 dBA (25% Load)
Product Dimensions	17.3 in. x 11.4 in. x 17.3 in.
Product Net Weight	37.5 Pounds

ENGINE

Engine Type	4 Stroke, OHV, Single Cylinder With Forced Aircooling System
Engine Displacement	80cc
Fuel Tank Capacity	1 Gallon (4L)
Oil Capacity	13.5 fl. oz. (400mL)
Half-Load Run Time	4.38 Hours
Lubrication System	Splash Lubrication
Spark Plug Type	Torch A5RTC (NGK CR5HS)
Spark Plug Gap	0.240 in. - 0.031 in. (0.6 - 0.8mm)
Spark Plug Torque	9.0 - 11.0 ft-lb (12 - 15 Nm)

INTRODUCTION

Thanks for purchasing the WEN 2500-Watt Inverter Generator. Refer to the illustration below for the location of the serial number on the specifications label. Record the generator information in the spaces provided below. If assistance for information or service is required, please contact customer service by calling **1-847-429-9263**, M-F 8-5 CST; you will be asked to provide the following generator information when calling.

Generator Model Number: 56250i

Date of Purchase: _____

Purchased From: _____

Serial Number: _____

SERIAL NUMBER →

2500W INVERTER GENERATOR				MODEL 56250i	
RATED WATTAGE	1900W	RATED FREQUENCY	60 Hz		
SURGE WATTAGE	2500W	RATED VOLTAGE	120V		
SERIAL NO.		SPARK PLUG TYPE	NGK CR5HS		
ENGINE SERIAL NO.		SPARK PLUG GAP	0.6mm - 0.8mm		
1-847-429-9263 WENPRODUCTS.COM			GÉNÉRATEUR ONDULEUR		TYPE 1 MADE IN VIETNAM
Great Lakes Technologies LLC • 1101 Wesemann Drive • West Dundee, IL 60118					

SERVICE RECORD

Record the service dates of your generator in the chart below. Please perform maintenance checks and operations according to the “Maintenance” section of the manual.

Service Record	Date	Date	Date	Date	Date	Date
Change Oil						
Change Spark Plug						
Clean Fuel Tank						
Clean Air Cleaner						
Clean Spark Arrestor						

TO MAXIMIZE THE LIFESPAN OF YOUR GENERATOR: We recommend running your generator at least once a month for 20 to 30 minutes. Start the generator according to the instructions and plug a small load in to make sure the outlet is producing electricity.

SAFETY INFORMATION

 **WARNING!** Before operating the generator, make sure to read all safety warnings and all instructions. Failure to follow the warnings and instructions may result in electric shock, fire or serious injury.

SAFETY INTRODUCTION

Safety is a combination of common sense, staying alert, and knowing how your tool works. This manual contains important information regarding the generator's potential safety concerns, as well as preparation, operation, and maintenance instructions. Before operating this generator, be sure to read and observe all warnings and instructions both on the generator labels and in this instruction manual. Failure to follow all instructions listed below may result in personal injury.

NOTE: The following safety information is not meant to cover all possible conditions and situations that may occur. WEN reserves the right to change this product and specifications at any time without prior notice.

At WEN, we are continuously improving our products. If you find that your tool does not exactly match this manual, please visit wenproducts.com for the most up-to-date manual or contact customer service at **1-847-429-9263**, M-F 8-5 CST.

Keep this manual available to all users during the entire life of the tool and review it frequently to maximize safety for both yourself and others.

SAVE THESE SAFETY INSTRUCTIONS.

SAFETY SYMBOLS

The purpose of following safety symbols is to attract your attention to possible dangers. The safety symbols, and their explanations, deserve your careful attention and understanding. The safety warnings do not by themselves eliminate any danger. The instructions or warnings they give are not substitutes for proper accident prevention measures.

 **DANGER:** indicates a hazard, which, if not avoided, will result in death or serious injury.

 **WARNING:** indicates a hazard, which, if not avoided, could result in death or serious injury.

 **CAUTION:** indicates a hazard, which, if not avoided, might result in minor or moderate injury.

CAUTION! when used without the alert symbol, indicates a situation that could result in damage to the machine.

NOTICE REGARDING EMISSIONS

Engines that are certified to comply with U.S. EPA emission regulations for SORE (Small Off Road Equipment), are certified to operate on regular unleaded gasoline, and may include the following emission control systems: (EM) Engine Modifications and (TWC) Three-Way Catalyst (if so equipped).

QUESTIONS? PROBLEMS?

In order to answer questions and solve problems in the most efficient and speedy manner, contact customer service at **1-847-429-9263**, M-F 8-5 CST or email techsupport@wenproducts.com.

GENERATOR SAFETY WARNINGS

DANGER! CARBON MONOXIDE

Using a generator indoors **CAN KILL YOU IN MINUTES**. Generator exhaust contains carbon monoxide (CO). This is a poison gas you cannot see or smell. If you can smell the generator exhaust, you are breathing CO. But even if you cannot smell the exhaust, you could be breathing CO.





NEVER use a generator inside homes, garages, crawl spaces, or other partially enclosed areas. Deadly levels of carbon monoxide can build up in these areas. Using a fan or opening windows and doors does **NOT** supply enough fresh air. **ONLY** use a generator outside and far away from windows, doors, and vents. These openings can pull in generator exhaust.

Even if you use a generator correctly, CO may leak into the home. **ALWAYS** use a battery-powered or battery-backup CO alarm in the home. If you start to feel sick, dizzy, or weak after the generator has been running, move to fresh air **RIGHT AWAY**. See a doctor. You may have carbon monoxide poisoning.

 **WARNING! RISK OF EXPLOSION. HIGHLY FLAMMABLE:** This generator may emit highly flammable and explosive gasoline vapors, which can cause severe burns or even death, if ignited. A nearby open flame can lead to explosion even if not directly in contact with gasoline.

- Do not operate near open flame, heat, or any other ignition source. Do not smoke near the generator.
- Always operate on a firm, level surface.
- Always turn generator off before refueling. Allow generator to cool for at least 2 minutes before removing fuel cap. Loosen cap slowly to relieve pressure in tank.
- Do not overfill fuel tank. Gasoline may expand during operation. Do not fill to the top of the tank. Allow for expansion. Always check for spilled fuel before operating.
- If fuel spills, move the generator at least 30 feet away from the spill and wipe clean any spilled fuel before starting the engine.
- Empty fuel tank before storing or transporting the generator.

 **WARNING!** If this generator is used as a supply for a building's wiring system, the generator must be installed by a qualified electrician and connected to a transfer switch as a separately derived system in accordance with all applicable laws and electrical codes and the National Electrical Code, NFPA 70. The generator shall be connected to a transfer switch that switches all conductors excluding the equipment grounding conductor. The frame of the generator shall be connected to an approved grounding electrode.

 **CALIFORNIA PROPOSITION 65 WARNING:** This product contains chemicals and produces exhaust known to the State of California to cause cancer, birth defects and other reproductive harm.

GENERATOR SAFETY WARNINGS

 **WARNING!** Do not let comfort or familiarity with the product replace strict adherence to product safety rules. Failure to follow the safety instructions may result in serious personal injury.

OPERATING ENVIRONMENT

1. Using a generator indoors can kill you in minutes.

Only use a generator outside and far away from windows, doors and vents.

2. Do not smoke near the generator.

3. Do not operate near open flame, heat, or flammable materials. This generator may emit highly flammable and explosive gasoline vapors, which can cause severe burns or even death if ignited. A nearby open flame can lead to an explosion even if it isn't directly in contact with gasoline.

4. Do not expose the generator to rainy or wet conditions; doing so significantly increases the risk of electrical shock. Never handle the generator, electronic devices, or any cord while standing in water, while barefoot, or when hands or feet are wet.

5. Always operate the generator on a dry, firm, level surface.

6. The generator should have at least 5 feet of clearance from buildings or other equipment during operation.

7. Do not allow children or non-qualified persons to operate the generator.

GENERATOR PREPARATION

1. Always ground the generator before using it to maximize safety (see "Ground the Generator" section).

2. Do not overfill fuel tank, as gasoline may expand during operation. Do not fill to the very top of the tank. Leave room for gasoline expansion. Always check for spilled fuel before operating.

3. If any part of the generator, electrical device or power cord is broken, damaged, or defective, make sure it is repaired or replaced before operation. Service should only be performed by a qualified technician. Do not use receptacles or cords that show signs of damage, such as broken or cracked insulation.

4. Use a ground fault circuit interrupter (GFCI) in highly conductive areas such as metal decking or steel work. Extension cords with in-line GFCIs are recommended for these operations to maximize safety.

5. If connecting the generator to a building's electrical system for standby power, you MUST consult a qualified electrician and install a transfer switch. Such connections must comply with local electrical laws and codes. Failure to comply can create a back-feed, which may result in serious injury or death to utility workers.

6. Never modify the generator in any way. Modifying or using the machine for any other purpose for which it is not designed may result in serious injuries, machine damage and voiding of the warranty.

GENERATOR OPERATION

1. Only use the generator for its intended purposes. Modifying or using the generator for operations for which it was not designed may cause hazards and personal injury.

2. Do not touch bare wires or receptacles (outlets).

3. Do not exceed the wattage capacity of the generator by plugging in more electrical devices than the unit can handle. This could damage the generator and/or connected electrical devices. Check the operating voltage and frequency requirements of all electrical devices prior to plugging them into the generator.

Generator safety warnings continue on the next page.

GENERATOR SAFETY WARNINGS

 **WARNING!** Do not let comfort or familiarity with the product replace strict adherence to product safety rules. Failure to follow the safety instructions may result in serious personal injury.

TO MAXIMIZE THE LIFESPAN OF YOUR GENERATOR: We recommend running your generator at least once a month for 20 to 30 minutes. Start the generator according to the instructions and plug a small load in to make sure the outlet is producing electricity. If you do not run it often, it will greatly shorten the generator's lifespan and void the warranty.

4. **Allow generator to run for several minutes before connecting electrical devices.** Do not start or stop engine with electrical devices plugged in to the receptacles. Failure to do so could damage the generator and/or connected electrical devices.
5. **Do not turn on electrical devices until after they are connected to the generator.**
6. **Generators vibrate in normal use.** During and after the use of the generator, inspect both the generator as well as extension and power supply cords for damage resulting from vibration.
7. **Do not touch hot parts.** This generator produces heat when running. Temperatures near exhaust can exceed 150°F (65°C). Allow generator to cool down after use before touching engine or areas of the generator that become hot during use.
8. **Turn off all connected electrical devices before stopping the generator.**
9. **Always turn generator off before refueling.** Allow generator to cool for at least 2 minutes before removing fuel cap. Loosen cap slowly to relieve pressure in tank.
10. **Turn the engine switch to “OFF” position when the engine is not running.**
11. **Empty fuel tank before storing or transporting the generator.** Do not store generator or gasoline near furnaces, water heaters, or any other appliances that produce heat or have automatic ignitions. Store the generator and fuel away from sparks, open flames, pilot lights, heat and other sources of ignition.
12. **Always wash hands after handling generator.**

CAUTION: Misuse of this generator can damage it or shorten its lifespan.

UNPACKING & PACKING LIST

UNPACKING

With the help of a friend or trustworthy foe, such as one of your in-laws, carefully remove the generator from the packaging and place it on a sturdy, flat surface. Make sure to take out all contents and accessories. Do not discard the packaging until everything is removed. Check the packing list below to make sure you have all of the parts and accessories. If any part is missing or broken, please contact customer service at **1-847-429-9263** (M-F 8-5 CST), or email techsupport@wenproducts.com.

PACKING LIST

Components

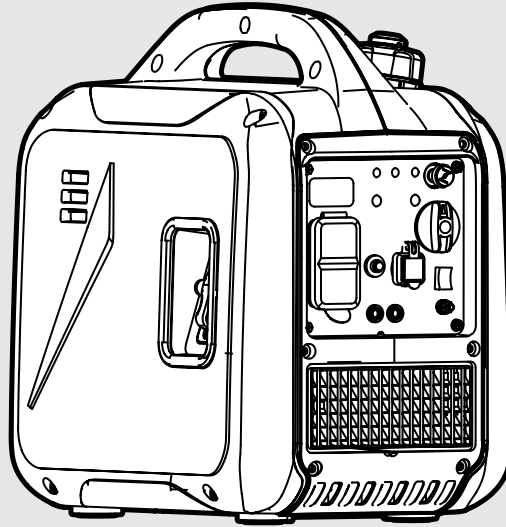

Generator

Spark Plug Tools



Handle



Wrench

Tools & Accessories

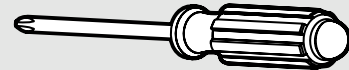

Screwdriver

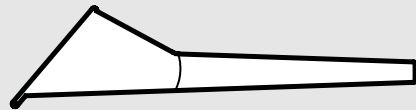

Funnel

KNOW YOUR INVERTER GENERATOR

TOOL PURPOSE

Inverter Generators provide you with clean and quiet power, when and where you need it most. Refer to the following diagrams to become familiarized with all the parts and controls of your generator. The components will be referred to later in the manual for assembly and operation instructions.

GENERATOR

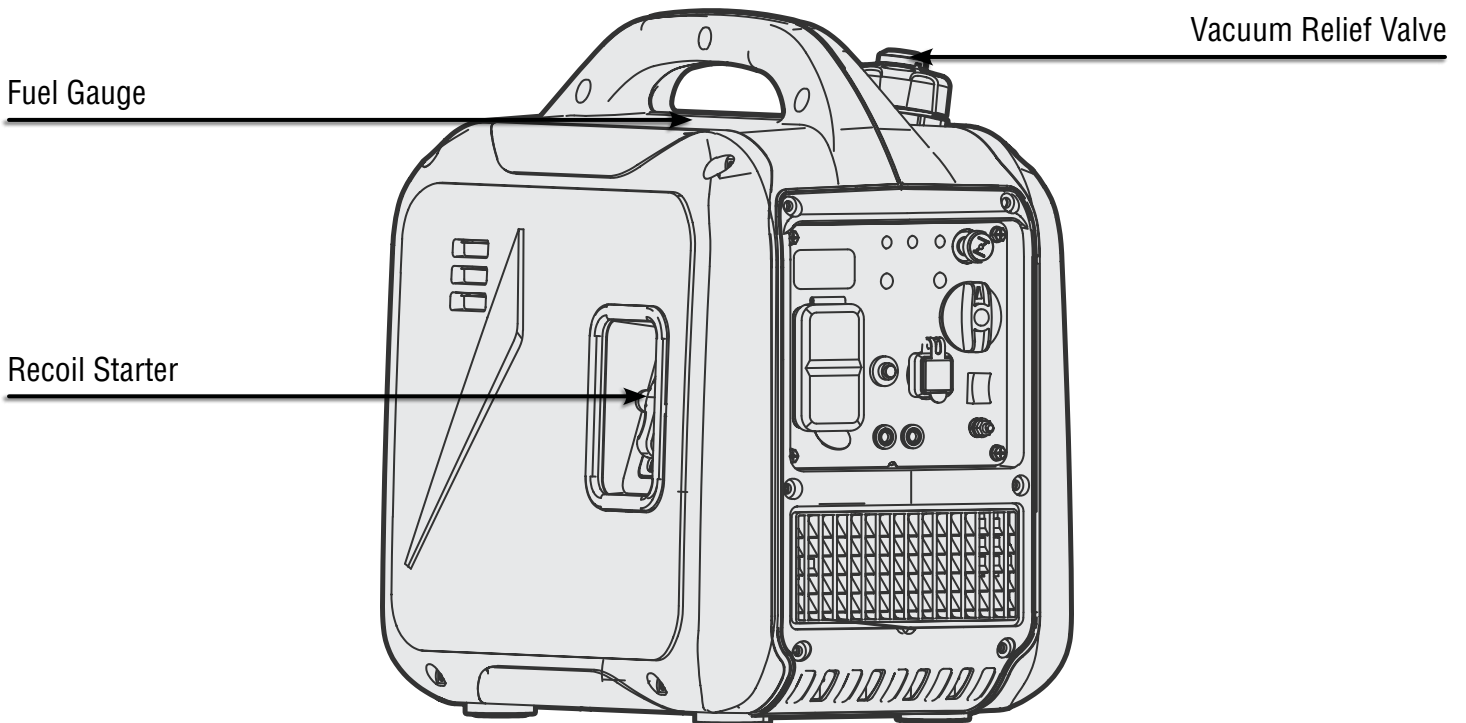
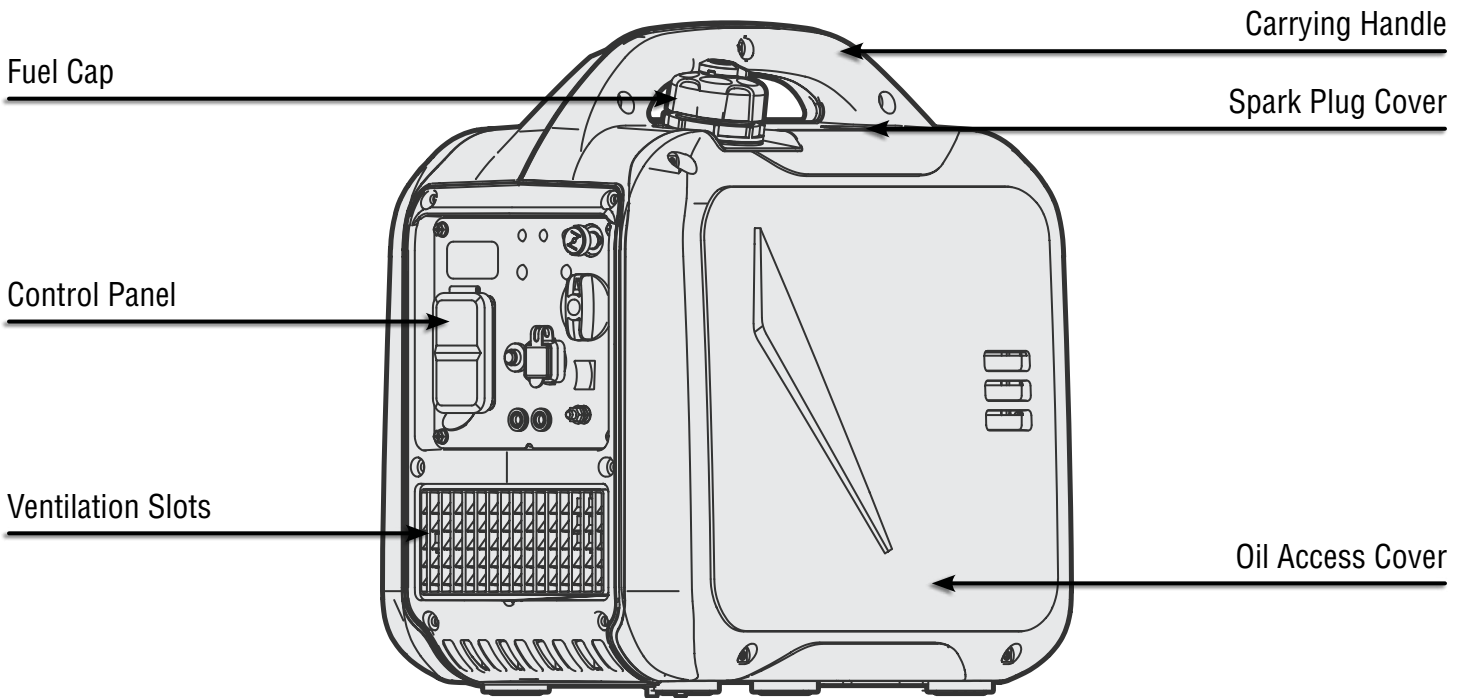

KNOW YOUR INVERTER GENERATOR

CONTROL PANEL

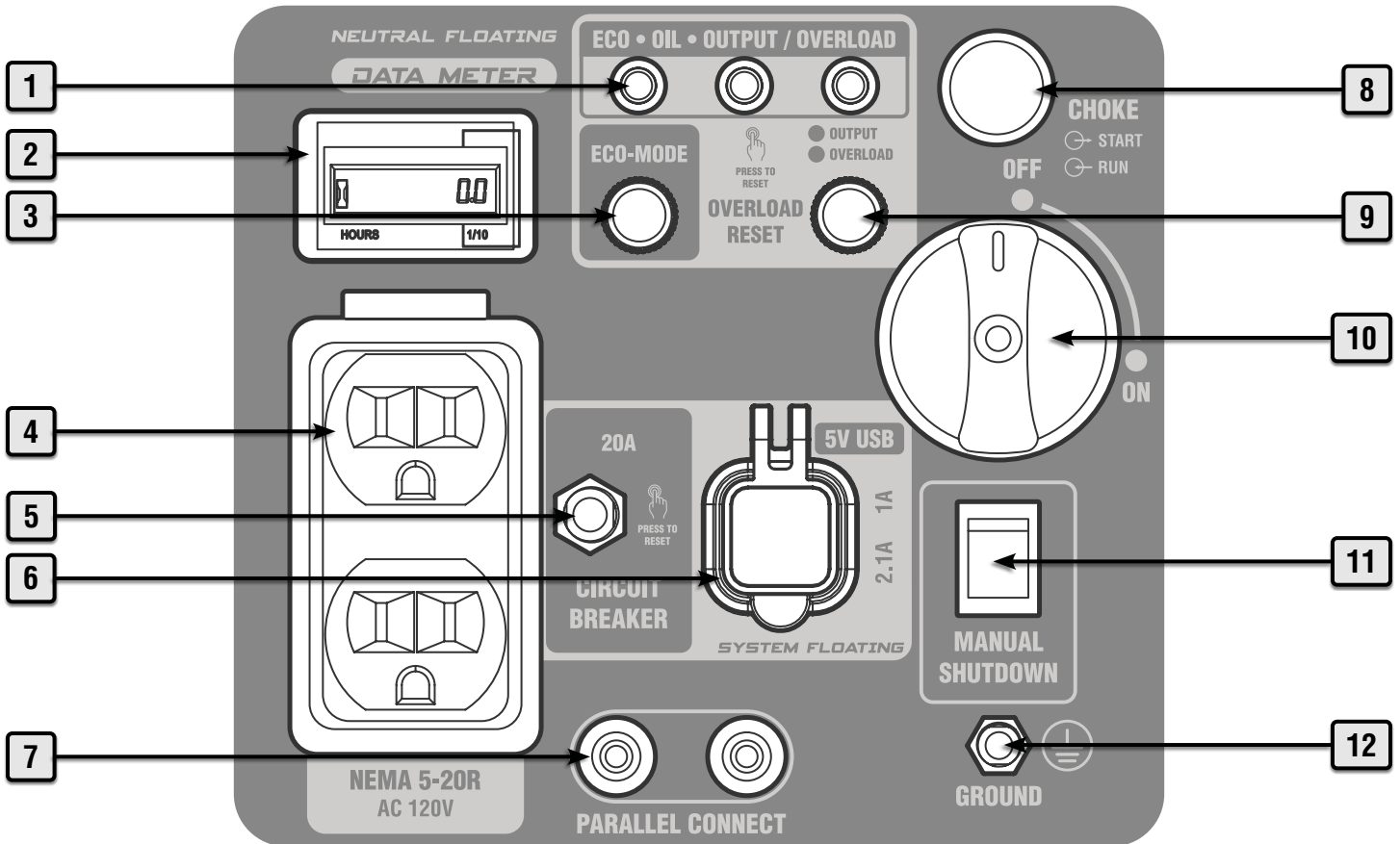

1. Indication Lights

- The ECO-MODE indicator light will light up when the ECO-MODE is ON. The generator automatically enters ECO-MODE upon startup.
- The OIL indicator light will light up when the oil level is low.
- The OUTPUT / OVERLOAD indicator light will light up GREEN to indicate that the generator has power and RED to indicate that the generator has been overloaded.

2. Hour Meter

Displays the number of hours the generator has run over its life.

3. Eco-Mode Button

Maximize fuel economy & run time. Press to toggle between ECO-MODE ON and OFF.

4. AC 120V Duplex NEMA 5-20R

Standard household outlets provide 120V 60Hz power.

5. AC Circuit Breaker, 20A

Press to reset the NEMA 5-20R outlets.

6. 5V USB Port

1A & 2.1A for charging various electronic devices.

7. Parallel Connection

Connect to share wattage between inverter generators.

8. Choke Lever

Use to start the engine.

9. Reset Button

Press to reset the circuit in case of overload.

10. Fuel Switch

Use to turn the fuel valve ON or OFF.

11. Manual Shutoff

Hold to manually shut OFF the generator.

12. Grounding Nut

Ground the generator to reduce the risk of electric shock.

GENERATOR PREPARATION

The following section describes the necessary steps to prepare the generator for use. If you are unsure about how to perform any of the steps please call **1-847-429-9263** M-F 8-5 CST for customer service. Failure to perform these steps properly can damage the generator or shorten its life.

STEP 1 - ADD / CHECK OIL

The generator is shipped without oil. User must add the proper amount of oil before operating the generator for the first time. The oil capacity of the engine crankcase is **13.5 fl. oz. (400mL)**.

ENGINE OIL RECOMMENDATIONS

Select good quality detergent oil bearing the American Petroleum Institute (API) service classifications SJ, SL, or SM (synthetic oils may be used). Select the SAE viscosity grade of oil that matches the expected operating temperature.

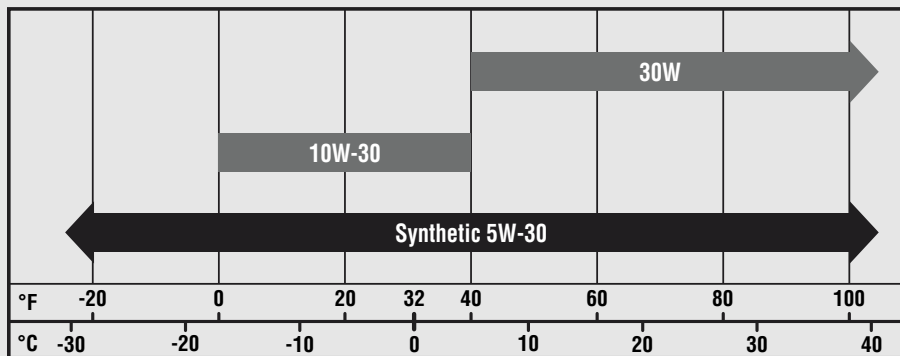

Fig. 1

- **30W Engine Oil**
Temperatures above 40°F
- **10W-30 Engine Oil**
Temperatures between 0°F - 40°F
- **Synthetic 5W-30 Engine Oil**
All temperature ranges

To add oil, follow these steps:

1. Place the generator on a level surface. Make sure the engine is OFF before adding or checking oil.

CAUTION! Keep the generator level! Tilting the generator to assist in filling will cause oil to flow into the engine areas and will cause damage.

2. Remove the screws from the right side panel and remove the panel to access the oil fill dipstick (Fig. 2).

3. Using an oil funnel or appropriate dispenser, slowly add oil into the oil fill, being careful not to overfill the unit. Fill the crank case to the upper fill line so you can visually see the oil coming halfway up the oil fill threads (Fig. 3).

4. Reinstall the oil dipstick and firmly tighten it. Wipe clean any spilled oil.

5. Reinstall the side panel and screws.

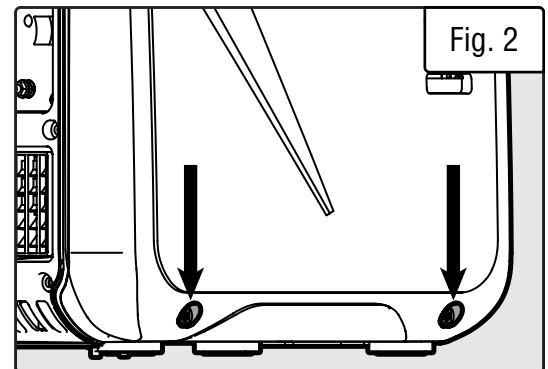

Fig. 2

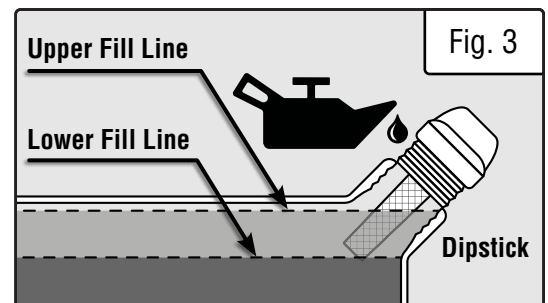

Fig. 3

GENERATOR PREPARATION

For subsequent operation, the oil level should be checked before each use, or after every 8 hours of operation. The generator is equipped with a low-oil sensor and will NOT start without a sufficient amount of oil.

To check oil level (before every subsequent start):

1. Place the generator on a level surface. Make sure the engine is OFF before adding or checking oil.
2. Open the oil access cover. Remove and wipe the dipstick with a clean rag.
3. Insert the dipstick into the oil fill without screwing it in. Remove the dipstick to check the oil mark (Fig. 4).

If the oil mark covers less than one half of the dipstick, slowly add oil until the oil mark reaches to the top of the dipstick (or when you can see the oil coming halfway up the oil fill threads).

4. Wipe clean any oil leaks and firmly tighten the dipstick. Reinstall the oil access cover.

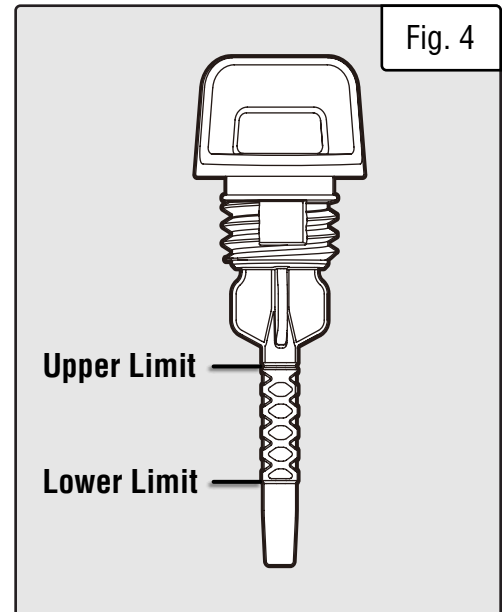

OIL LEVEL SHUTDOWN

To protect the unit from damage, the generator is equipped with a low-oil-pressure shutoff that will automatically stop the engine when the oil level is too low. The low oil indication light will turn on to remind you that the engine oil level is low and need to be refilled.

The oil level of the engine should be checked before each start to ensure that the engine crankcase contains sufficient lubricant.

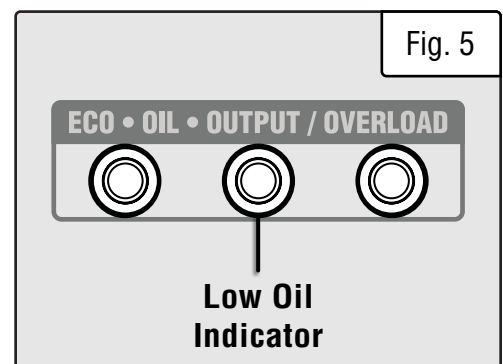

TIP: Your WEN generator is compatible with the **WEN 55201** Magnetic Oil Dipstick (not included), available for purchase at wenproducts.com. The dipstick's industrial-strength magnetic tip will collect metal shavings from your generator's oil tank to help preserve the engine and extend your generator's lifespan.

GENERATOR PREPARATION

STEP 2 - ADD / CHECK FUEL

⚠ WARNING! RISK OF EXPLOSION. HIGHLY FLAMMABLE: This generator may emit highly flammable and explosive gasoline vapors, which can cause severe burns or even death, if ignited. A nearby open flame can lead to explosion even if not directly in contact with gasoline.

- Do not operate near open flame, heat, or any other ignition source. Do not smoke near the generator.
- Always operate on a firm, level surface.
- Always turn generator off before refueling. Allow generator to cool for at least 2 minutes before removing fuel cap. Loosen cap slowly to relieve pressure in tank.
- Do not overfill fuel tank. Gasoline may expand during operation. Do not fill to the top of the tank. Allow for expansion. Always check for spilled fuel before operating.
- If fuel spills, move the generator at least 30 feet away from the spill and wipe clean any spilled fuel before starting the engine.
- Empty fuel tank before storing or transporting the generator.

ONLY use fresh (within 30 days from purchase), lead-free gasoline with a **minimum of 87 octane rating**. The generator performs best with ethanol-free gasoline. **DO NOT** use gasoline with over 10% ethanol.

The capacity of the fuel tank is **1 Gallon (4L)**. Do not mix oil with gasoline.

To add gasoline, follow these steps:

1. Make sure the generator is shut OFF and on a level surface. Unscrew the fuel cap (Fig. 6) and set it aside. The fuel cap may be tight and hard to unscrew.
2. Slowly add unleaded gasoline to the fuel tank. Be careful not to overfill.

NOTE: Do not fill the fuel tank to the very top. If you do so, gasoline will expand and spill during use, even with the fuel cap in place.

3. Reinstall fuel cap and wipe clean any spilled gasoline with a dry cloth.

IMPORTANT:

- Avoid getting dirt or water into the fuel tank.
- Keep gasoline away from sparks, open flames, pilot lights, heat, and other sources of ignition.
- Gasoline can age in the tank and make starting difficult. Never store the generator for more than 2 months with fuel in the tank.
- Never use an oil/gasoline mixture.
- Never use old gasoline.

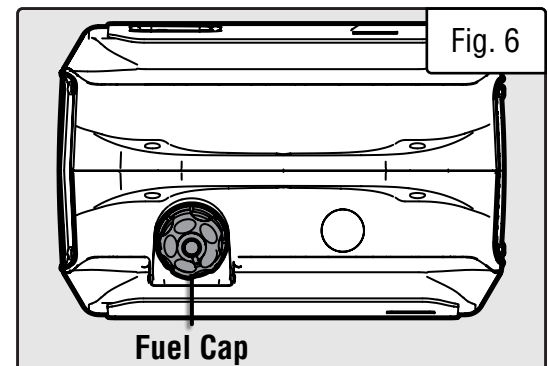

GENERATOR PREPARATION

STEP 3 - GROUND THE GENERATOR

To reduce the risk of electric shock and to maximize safety, the generator should be properly grounded.

Ground the generator by tightening the grounding nut (Fig. 7 - 1) on the front control panel against a grounding wire. A generally acceptable grounding wire is a **No. 12 AWG (American Wire Gauge) stranded copper wire**.

This grounding wire should be connected at the other end to a copper, brass, or steel-grounding rod that is driven into the earth. Wire and grounding rods are not included with the generator.

NOTE: Grounding codes can vary by location. Contact a local electrician to check the area codes.

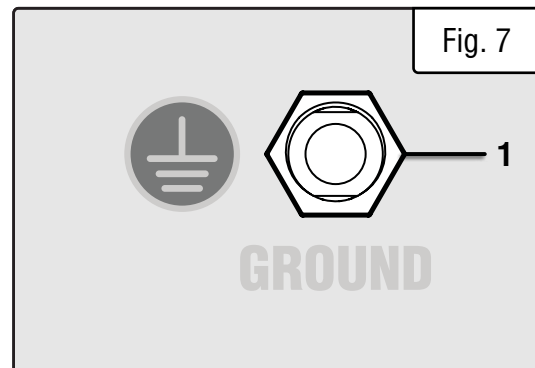

⚠ WARNING! Failure to properly ground the generator increases your risk of electric shock.

HIGH ALTITUDE OPERATION ABOVE 3000 FEET

The fuel system on this generator may be affected by operation at high altitudes. Proper operation can be ensured by installing an altitude kit at altitudes higher than 3000 feet above sea level. At elevations above 8000 feet, the engine may experience a decrease in performance, even with the proper altitude kit. Operating this generator without said kit may increase the engine's emissions and decrease both fuel economy and performance.

This kit should be installed by a qualified mechanic. You can order the kit at **wenproducts.com** by searching part **56250i-HA36** for 3000 to 6000 feet above sea level or **56250i-HA68** for 6000 to 8000 feet above sea level. Refer to the instructions included with your altitude kit for more information about installation.

⚠ WARNING! To prevent serious injury from fire, follow the kit installation procedures in a well-ventilated area away from ignition sources. If the engine is hot from use, shut the engine off and wait for it to cool before proceeding. Do not smoke near the generator. Warranty will be void if adjustments are not made for high altitude use.

CAUTION: Engines with the high-altitude kit installed operated at lower altitudes could cause severe engine damage and affect emissions compliance. Be sure to UNINSTALL the high altitude kit when operating at altitudes below 3000 feet.

After completing the above preparation, the generator is ready to be started.

STARTING YOUR GENERATOR

Before starting the generator, make sure you have read and performed the steps in the “Generator Preparation” section of this manual. If you are unsure about how to perform any of the steps in this manual please call **1-847-429-9263** M-F 8-5 CST for customer service.

DANGER! CARBON MONOXIDE

Using a generator indoors **CAN KILL YOU IN MINUTES**. Generator exhaust contains carbon monoxide (CO). This is a poison gas you cannot see or smell. If you can smell the generator exhaust, you are breathing CO. But even if you cannot smell the exhaust, you could be breathing CO.

NEVER use a generator inside homes, garages, crawl spaces, or other partially enclosed areas. Deadly levels of carbon monoxide can build up in these areas. Using a fan or opening windows and doors does NOT supply enough fresh air. **ONLY** use a generator outside and far away from windows, doors, and vents. These openings can pull in generator exhaust.

Even if you use a generator correctly, CO may leak into the home. **ALWAYS** use a battery-powered or battery-backup CO alarm in the home. If you start to feel sick, dizzy, or weak after the generator has been running, move to fresh air **RIGHT AWAY**. See a doctor. You may have carbon monoxide poisoning.

 **WARNING!** The exhaust from this product contains chemicals known to the State of California to cause cancer, birth defects, or other reproductive harm.

 **WARNING!** Do not operate generator near open flame or flammable materials. This generator may emit highly flammable and explosive gasoline vapors, which can cause severe burns or even death if ignited. A nearby open flame can lead to explosion even if it isn't directly in contact with gasoline. Do not smoke near the generator.

 **WARNING!** This generator produces powerful voltage, which can result in electrocution.

 **WARNING!** Do not use in rainy or wet conditions. Do not touch bare wires or receptacles (outlets). Do not allow children or non-qualified persons to operate.

 **WARNING!** Generator should only be connected to electrical devices, either directly or with an extension cord. **NEVER** connect to a building electrical system without a qualified electrician and connected to a transfer switch as a separately derived system. Such connections must comply with local electrical laws and codes. Failure to comply can create a back-feed, which may result in serious injury or death to utility workers.

To maximize safety, **ALWAYS** ground the generator before using it. See section “Ground the Generator”.

Use a ground fault circuit interrupter (GFCI) in highly conductive areas such as metal decking or steel work. GFCIs are available in-line with some extension cords.

CAUTION! Disconnect all electrical loads from the generator before attempting to start.

Follow the instructions on the next page to start your generator.

STARTING YOUR GENERATOR

BEFORE STARTING THE GENERATOR

1. Verify that the generator is outside on a dry, level surface. Allow at least two feet of clearance on all sides of the generator.
2. To maximize safety, check that the generator is properly grounded. See page 15, "GROUND THE GENERATOR."
3. Check that there is a sufficient level of oil in the crankcase. Add oil if necessary. Refer to page 12, "STEP 1 - ADD / CHECK OIL."
4. Check that there is a sufficient level of fuel in the fuel tank. Add gas if necessary. Refer to page 14, "STEP 2 - ADD / CHECK FUEL".
5. Make sure all electrical devices are unplugged from the generator during ignition. Otherwise it will be difficult for the engine to start.

STARTING THE GENERATOR

1. Turn the FUEL SWITCH (Fig. 8 - 1) to ON.
2. Open the vacuum relief valve (Fig. 9 - 1) on the fuel tank cap.
3. Pull the CHOKE (Fig. 8 - 2) out to the START position.
4. Place one hand on the generator to hold it in place, and pull on the recoil starter handle (Fig. 10 - 1) slowly until a slight resistance is felt. Then pull quickly to start the engine. Return the cord gently into the machine. Never allow the cord to snap back.
5. Push the CHOKE in to the RUN position.
6. Allow the generator to run for several minutes before attempting to connect any electrical devices. This allows the generator to stabilize its speed and temperature.

NOTE: If you have repeated failed attempts to start the engine, please consult the troubleshooting guide. If problems persist, please call **1-847-429-9263 M-F 8-5 CST.**

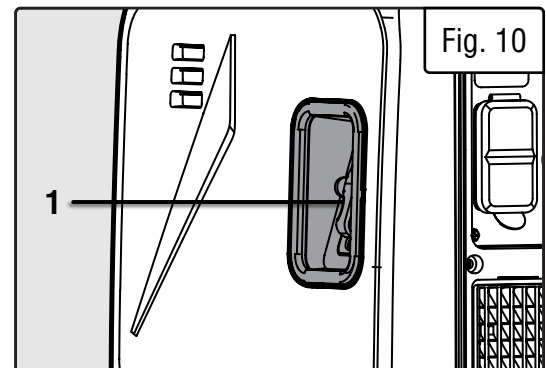
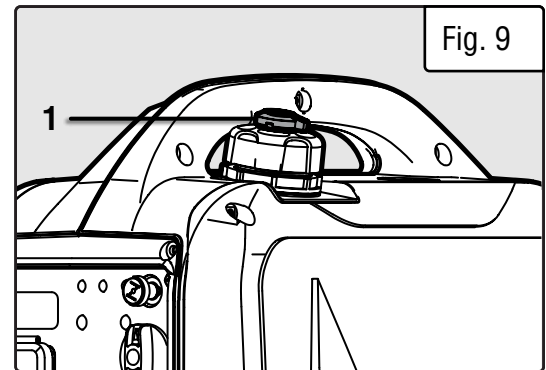
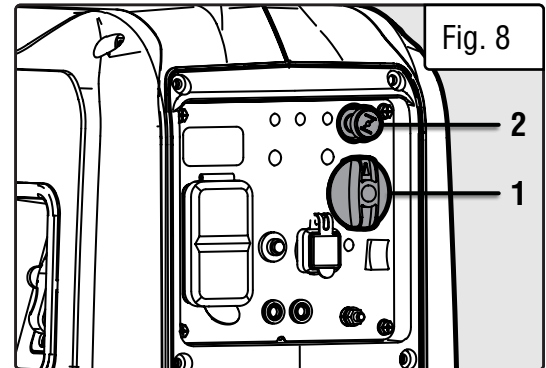

USING YOUR GENERATOR

CALCULATING THE WATTAGE OF YOUR DEVICE(S)

Connect electrical devices running on AC current according to their wattage requirements. Calculate the total running wattage and starting wattage of the device(s) you wish to connect, and **MAKE SURE** that they are within the capacity of your generator and the capacity of each individual outlet.

Generator Wattage Capacity	GENERATOR RUNNING (RATED) WATTS	GENERATOR STARTING (SURGE) WATTS
		1900W
	<p>What this means: The generator can produce a maximum of 1900W on a continuous basis to supply on-going power to your electronic devices.</p> <p>NOTE: Also check the rated amperage for each outlet and make sure not to overload the individual outlets.</p>	<p>What this means: Some devices such as box fans require short bursts of extra power in addition to the rated wattage listed by the device to start their motors.</p> <p>The generator can produce a maximum wattage of 2500W for a short period of time (seconds) to cover the extra starting power required by your electronic devices.</p>
Electronic Device Wattage Calculation	<p>Find the wattage information of each device you plan to connect. The information should be listed on the device or in its instruction manual, or you may refer to page Table 2.</p> <p style="text-align: center;">The wattage can be calculated using this equation: Watts = Volts x Amperes</p>	
	<p>To calculate the total running watts of your devices:</p> <p>+ Add up the running wattages of all the device(s) you plan to connect.</p> <p>= The total running (rated) wattage.</p> <p>This wattage should NOT exceed the running wattage of 1900W.</p> <p>It is recommended to maintain a load at or below 1710W (90% of the rated output) to ensure steady voltage output and to prolong the generator's lifespan.</p>	<p>To calculate the total starting watts of your devices:</p> <p>+ Add up the total running wattage of all the device(s) you plan to connect.</p> <p>+ Add the single highest ADDITIONAL starting wattage out of the device(s) you plan to connect.</p> <p>= The total starting (surge) wattage.</p> <p>This wattage should NOT exceed the starting wattage of 2500W.</p>
	<p>If any of either of the total calculated running watts or starting watts is higher than the capacity of your generator, adjust the load until both wattage requirements are met. Otherwise you will overload the generator, and cause damage to the engine and your electrical device(s).</p>	

Table 1 - How to Calculated Wattages

USING YOUR GENERATOR

CALCULATING THE WATTAGE OF YOUR DEVICE(S) - CONTINUED

The chart below serves as a reference for the estimated wattage requirements of common electrical devices. However, do not solely rely on this chart - all electronics and appliances are built differently. Always check the wattage listed on the electrical device before consulting this chart.

Tool or Appliance	Rated (Running) Watts	Surge (Starting) Watts
Electric Water Heater (40 Gal)	4000	0
Hot Plate	2500	0
Saw - Radial Arm	2000	2000
Electric Stove (Each Element)	1500-2800	0
Saw - Circular	1500	1500
Air Compressor (1 HP)	1500	3000
Window Air Conditioner	1200	1800
Saw - Miter	1200	1200
Microwave	1000	0
Well Water Pump	1000	1000
Sump Pump	800	1200
Refrigerator Freezer	800	1200
Furnace Blower	800	1300
Computer	800	0
Electric Drill	600	900
Television	500	0
Deep Freezer	500	500
Garage Door Opener	480	0
Stereo	400	0
Box Fan	300	600
Clock Radio	300	0
Security System	180	0
DVD Player / VCR	100	0
Common Light Bulb	75	0

Table 2 - Estimated Wattages of Common Electrical Appliances

NOTE: Become familiar with the functions and capacity of each component on the control panel before connecting electrical devices. See page 11 for more information about the components of the control panel. Do not overload generator or individual panel receptacles. Do not connect 50Hz or 3-phase loads to the generator.

USING YOUR GENERATOR

CONNECTING ELECTRICAL DEVICES

When the rated wattage requirement of each electrical device has been determined, add these numbers to find the total rated wattage needed. If this number exceeds the rated wattage (1900W) of the generator, DO NOT connect all these devices. Select a combination of electrical devices with a total rated wattage lower than or equal to the rated wattage of the generator.

⚠ CAUTION! Become familiar with the markings on the control panel before connecting electrical devices. Do not connect 50Hz loads to the generator.

1. Before connecting electrical devices, allow the generator to run for a few minutes to stabilize the speed and voltage output.
2. Make sure that all devices are turned OFF. Start plugging in each electric device, from the highest wattage to the lowest. Check the output indicator light (green) to ensure the generator is producing power.
3. Do not overload the generator or individual panel receptacles. If an overload occurs, the overload indicator light (red) will activate. If it is flashing, turn OFF and unplug one load. If it is solid (not flashing), the generator will cut off power to protect itself. Unplug all electrical devices and then press the reset button to reset the entire circuit. Check the total wattage of the devices and reduce the load if it exceeds the capacity of the generator. Then, plug the loads back in one by one.

NOTE: If the reset button or circuit breaker does not reset, wait several minutes and try again. If problem still persists, please call **1-847-429-9263** M-F 8-5 CST.

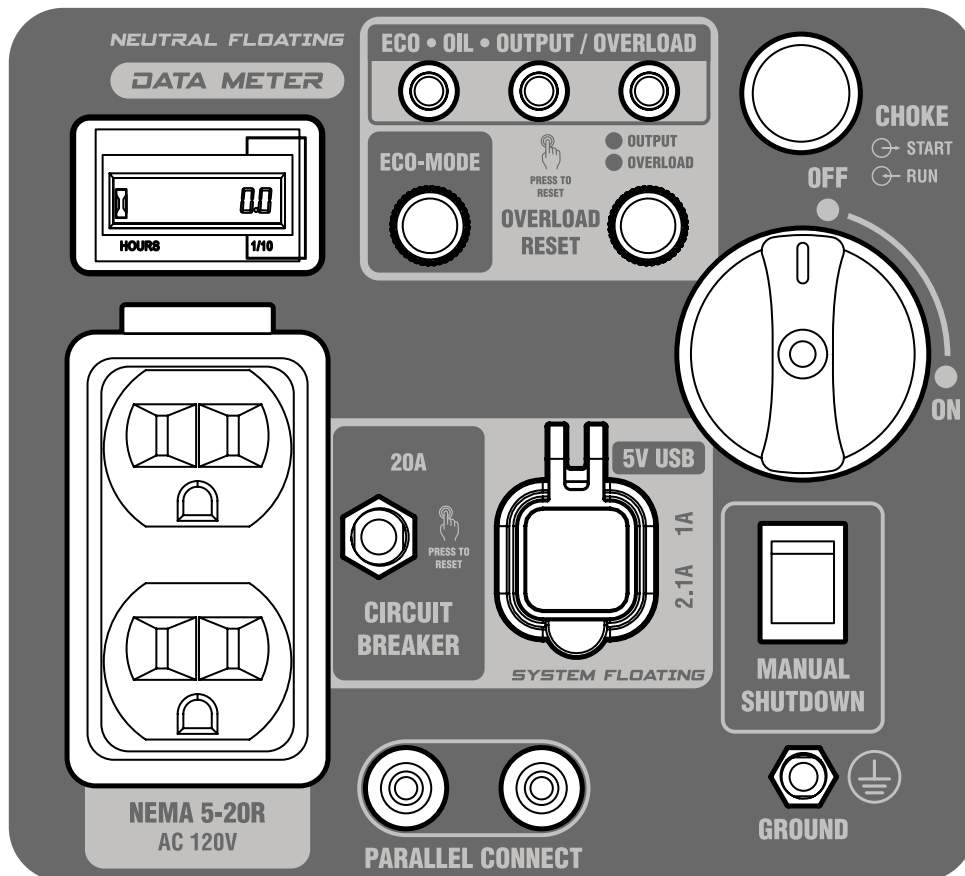

USING YOUR GENERATOR

ECO-MODE BUTTON

This generator is equipped with an Eco-Mode Idle Control Button. Engaging this button allows the system to regulate the engine speed and automatically adjust its fuel consumption to match the required load. When the electrical load changes, the generator engine will automatically speed up and slow down as needed. This reduces fuel consumption and noise levels, while extending runtime and engine's lifespan.

Keep this switch engaged **ONLY** when the power load requirement is **LESS THAN 1685W** (75% of the rated watts). Do not engage the Eco-Mode Switch when the total load is more than 1685W. The generator engine must run at full speed to supply power for anything over 1685W.

NOTE: The generator automatically turns Eco-Mode ON when it starts up.

PARALLEL OPERATION

The parallel connection ports allow you to connect two WEN generators to increase the total available electrical power. The **WEN Parallel Connection Kit** can be purchased from **wenproducts.com**. Follow the instructions included with your parallel connection kit for proper installation and operation.

IN CASE OF OVERLOAD

If your generator becomes overloaded from too much drawn wattage, the overload indicator (red) on the control panel will light up, and the overload reset button on your control panel may activate and cut off the output. When an overload occurs, reduce the load by turning off and unplugging your electronic device(s), then press the reset button to reset your generator. If no power is produced after resetting, restart your generator.

- **Slightly Over Rated Wattage:** Overload light will flash to indicate overload
- **Significantly Over Rated Wattage:** Overload light will turn on for several seconds, then output will be cut off.

ENGINE BREAK-IN PROCEDURE

The procedure below should be followed when you receive your generator in order to prolong the engine's service life. This procedure helps to seat the piston rings properly in the cylinder, and will reduce overall wear on the engine.

For the first 8 hours of operation, vary the load, but keep it at or below 50% of the generator's rated wattage, if possible. If your generator is equipped with an Eco-mode switch (only applicable for certain inverter generators), engage Eco-mode periodically during the first 8 hours. After the first 8 hours, change the oil, then change it again after the first 25 hours. You may run the generator at full load after the 8-hour oil change. Refer to the Recommended Maintenance Schedule in Table 4 for the full maintenance schedule.

USING YOUR GENERATOR

SOME NOTES ABOUT POWER CORDS

Long or thin cords can drain the power provided to an electrical device by the generator. When using such cords, allow for a slightly higher rated wattage requirement by the electrical device.

Device Requirements			Max. Cord Length (ft) by Wire Gauge				
Amps	Watts (120V)	Watts (240V)	#8 Wire	#10 Wire	#12 Wire	#14 Wire	#16 Wire
2.5	300	600	NR	NR	NR	375	250
5	600	1200	NR	NR	300	200	125
7.5	900	1800	NR	350	200	125	100
10	1200	2400	NR	250	150	100	50
15	1800	3600	NR	150	100	65	NR
20	2400	4800	175	125	75	50	NR
25	3000	6000	150	100	60	NR	NR
30	3600	7200	125	65	NR	NR	NR
40	4800	9600	90	NR	NR	NR	NR

*NR = Not Recommended

Table 3 - Power Cord Requirement Guide

⚠ WARNING! Generator should **only** be connected to electrical devices, either directly or with an extension cord. NEVER CONNECT TO A BUILDING ELECTRICAL SYSTEM without a qualified electrician and connected to a transfer switch as a separately derived system. Such connections must comply with local electrical laws and codes. Failure to comply can create a back-feed, which may result in serious injury or death to utility workers.

NOTE: For power outages, permanently installed, stationary generators are better suited for providing backup power to your home. Even a properly connected portable generator can become overloaded. This may result in overheating or stressing the machine's components, possibly leading to generator failure.

SHUTTING OFF YOUR GENERATOR

⚠ CAUTION! Unplugging running devices can cause damage to the generator. Never stop the engine with electrical devices connected and running.

OPTION 1: AUTOMATIC FUEL SHUTOFF

1. Turn off all electrical devices and then unplug the devices from the generator.
2. Allow the generator to run at no load for a few minutes to stabilize the internal temperatures.
3. Turn the FUEL SWITCH (Fig. 12 - 1) to the OFF position.
4. Close the vacuum relief valve (Fig. 13 - 1) on top of the fuel cap by rotating it counterclockwise to the OFF position.
4. The engine will continue to run until the majority of the fuel in the carburetor is consumed, which takes a few minutes. It will then shut off automatically. This feature helps to prevent the carburetor from being clogged by stale fuel, extending your generator's lifespan.

OPTION 2: AUTOMATIC FUEL SHUTOFF

In case you are in a hurry and do not want to wait for the generator to automatically shut down, the manual shutoff feature is available. However, this method will leave stagnant fuel in the carburetor, possibly causing blockages, a shortened lifespan, and other maintenance issues. If this approach is frequently taken, make sure to drain your carburetor before any long storage periods.

1. Turn off all electrical devices prior to unplugging them from the generator. Unplugging running devices can cause damage to the generator.
2. Turn the MANUAL SHUTOFF switch (Fig. 12 - 2) to the OFF position. Hold the switch in the OFF position for about six seconds until the engine shuts off.

⚠ WARNING! Allow the generator to cool for several minutes before touching areas that become hot during use.

⚠ CAUTION! Allowing gasoline to sit in the fuel tank for long periods of time can make it difficult to start the generator in the future. Never store the generator for extended periods of time (over 2 months) with fuel in the fuel tank. Refer to "Storing the Generator".

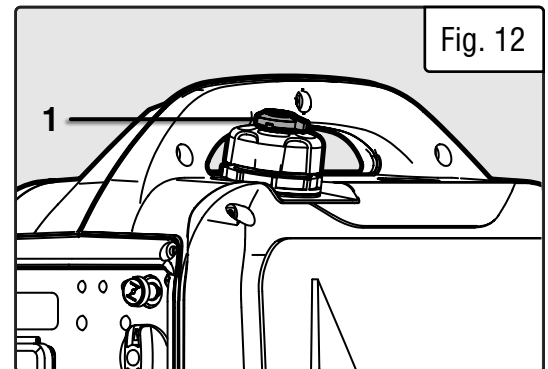
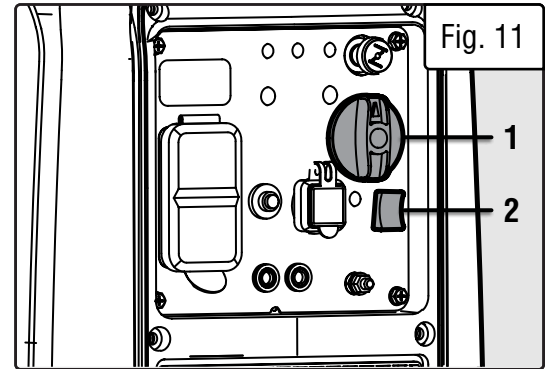

MAINTENANCE

Proper routine maintenance of the generator will help prolong the life of the machine. Please perform maintenance checks and operations according to the schedule in Table 4.

⚠ CAUTION! Never perform maintenance operations while the generator is running. Before maintaining or servicing the generator, turn OFF the generator, disconnect all devices and allow the generator to cool down.

If there are any questions about the maintenance procedures listed in this manual, please call **1-847-429-9263** M-F 8-5 CST or email techsupport@wenproducts.com.

Recommended Maintenance Schedule		Every 8 Hours or Daily	Every 25 Hours	Every 3 Months or 50 Hours	Every 6 Months or 100 Hours	Before Storage	As Necessary
Engine Oil	Check Level	x					
	Replace		x*				x
Air Filter	Check			x*			
	Clean			x*			
Spark Plug	Check/Clean/Regap				x		
	Change				x		x
Fuel	Check Level	x					
	Drain					x	x
Carburetor	Drain	x					x
Spark Arrestor	Check/Clean				x		

* Clean/change more often under dusty conditions or operating under heavy load.

Table 4 - Recommended Maintenance Schedule

IMPORTANT GENERATOR MAINTENANCE TIPS:

- Drain your carburetor after each use and before storage to prevent it from clogging.
- Do not store the generator with fuel inside the tank for more than 2 months - the fuel will go bad.
- Run the generator for at least 15 minutes every month to maximize its lifespan.

CLEANING THE GENERATOR

Keep the generator clean to prevent improper operation or machine damage from dirt and debris. Inspect all ventilation openings on the generator. These openings must be kept clean and unobstructed. If the generator becomes dirty, use a damp cloth to wipe exterior surfaces. Use a soft bristle brush to loosen dirt and oil and use a vacuum to pick up loose dirt. Use low pressure air (not to exceed 25 PSI) to blow away dirt.

⚠ CAUTION! Never clean the generator when it is running! Never clean with a bucket of water or a hose. Water can get inside the working parts of the generator and cause corrosion or a short circuit.

NOTE: Failure to properly maintain the generator will void the warranty.

MAINTENANCE

CLEANING THE GENERATOR

Keep the generator clean to prevent improper operation or machine damage from dirt and debris. Inspect all ventilation openings on the generator. These openings must be kept clean and unobstructed.

If the generator becomes dirty, use a damp cloth to wipe exterior surfaces. Use a soft bristle brush to loosen dirt and oil and use a vacuum to pick up loose dirt. Use low pressure air (not to exceed 25 PSI) to blow away dirt.

⚠ WARNING! Never clean generator when it is running! Never clean with a bucket of water or a hose. Water can get inside working parts of the generator and cause corrosion or a short circuit.

CHECKING/ADDING OIL

Check the oil level before each use and every 8 hours of operation (refer to Table 4).

The oil capacity of the generator engine is **13.5 fl. oz. (400mL)**. Add oil when the oil level is low. For proper type and weight of oil refer to “ADD OIL” portion of the “GENERATOR PREPARATION” section. This is a critical step for proper engine starting. The generator is equipped with an automatic shutoff to protect it from running on low oil.

To check the oil level and add oil:

1. Make sure the generator is on a level surface. Do not tilt the generator, as oil will flow into engine areas and cause damage. Keep generator level!
2. Pull down and out on the release tab at the top of the oil access cover. Then unscrew the oil dipstick from the engine.
3. Insert the dipstick into the oil fill opening without screwing in. Remove the dipstick to check the oil mark (Fig. 14). Add oil if the oil mark covers less than one half of the dipstick.
4. Using a funnel or appropriate dispenser, slowly add more oil. Repeat step 2 until the oil mark reaches the top of the dipstick (you can see oil coming up the threads of the oil fill). Do not over fill.
5. Reinstall dipstick and wipe clean any spilled oil with a rag. Reinstall the oil access cover.
6. Reinstall the oil access cover.

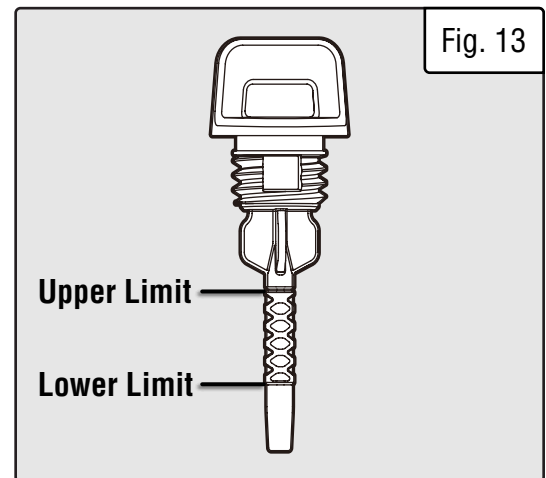

TIP: Your WEN generator is compatible with the **WEN 55201** Magnetic Oil Dipstick (not included), available for purchase at wenproducts.com. The dipstick's industrial-strength magnetic tip will collect metal shavings from your generator's oil tank to help preserve the engine and extend your generator's lifespan.

DRAINING THE CARBURETOR

We recommend draining the carburetor after every use (not necessary if the generator is shut off using the “FUEL OFF” option), and before storing the generator. Draining the carburetor can prevent the fuel from clogging up the carburetor and preventing the generator from starting.

1. Place generator on an elevated platform such as table or desk.
2. Using a Phillips-head screwdriver, remove the two screws on the right side panel as shown in Fig. 15.
3. Locate the carburetor (Fig. 16 - 1) and the clear drain tube (Fig. 16 - 2).
4. Prepare an approved gasoline-storage container and direct the end of the drain tube into the container.
5. Open up the carburetor drain screw (Fig. 16 - 3) with a Phillips-head screwdriver and drain out any gasoline that has built up inside the carburetor through the drain tube into the approved gasoline-storage container.
6. Once the fuel has drained, tighten the drain screw with the screwdriver.
7. Reinstall the side panel and screws.
8. Reinstall the side panel and screws.

NOTE: Make sure to drain your carburetor before storing the generator for long periods of time.

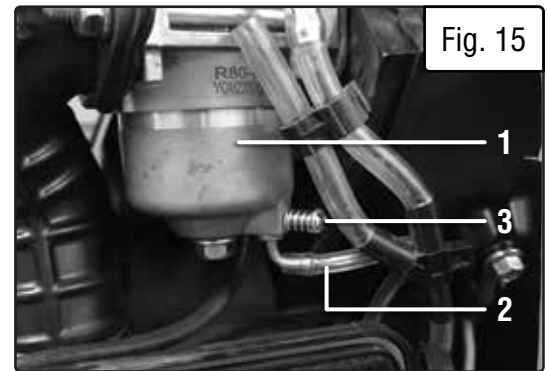
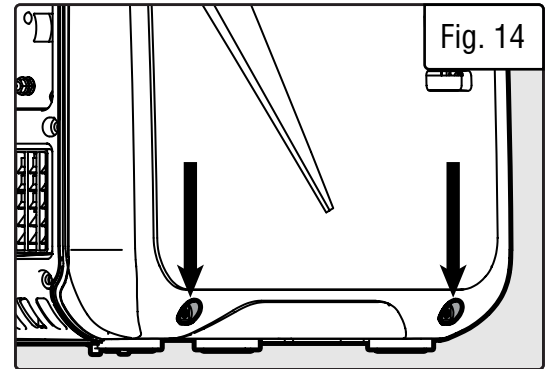

MAINTENANCE

AIR FILTER MAINTENANCE

Check every 50 hours of operation (refer to Table 4 - Recommended Maintenance Schedule).

Routine maintenance of the air filter helps maintain proper airflow to the carburetor. Occasionally check that the air cleaner is free of excessive dirt.

To inspect and clean the air filter:

1. Using a Phillips-head screwdriver, remove the two screws on the right side panel as shown in Fig. 15.
2. Take the cover off of the air filter (Fig. 17 - 1) using the two tabs on both sides. Remove the air filter element. Wipe excessive oil and any dirt from inside of the air filter casing.
3. Check and clean the foam air filter element. Good elements can be washed in soapy water, dried and reused. A small amount of oil in the element is normal and necessary for the engine to work properly.

If the air filter element has been damaged, replace it with a new one. Replacement air filters can be ordered from wenproducts.com by searching **part no. 56250i-0504**.

4. Reinstall the air filter element, air filter cover and side panel.

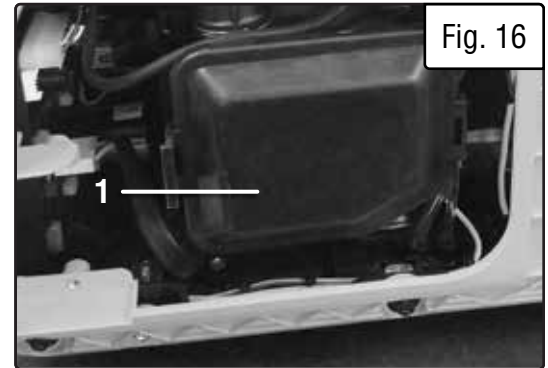

⚠ WARNING! Running the engine with a dirty, damaged or missing air filter element can result in danger to the operator and cause the engine to wear out prematurely.

DRAINING/CHANGING OIL

Change the oil according to the Recommended Maintenance Schedule in Table 4.

Change the oil MORE OFTEN if operating under heavy load or high ambient temperatures. It is also necessary to drain the oil from the crankcase if it has become contaminated with water or dirt. Changing the oil when the engine is warm allows for complete drainage.

1. Close the gas cap.
2. Place the generator on an elevated platform such as a table or workbench. Prepare an oil pan to catch the oil as it drains.

NOTE: To avoid possible fuel spills from the carburetor bowl, drain the carburetor before draining oil.

3. Using a Phillips-head screwdriver, remove the two screws on the right side panel as shown in Fig. 15.
4. Remove the dipstick (Fig. 18 - 1) and tilt the generator towards you and allow the oil to drain from the engine completely.

NOTE: Never dispose of used motor oil in the trash or down a drain. Please call a local recycling center or auto garage to arrange proper oil disposal.

5. Using a funnel or appropriate dispenser, add **13.5 fl. oz. (400mL)** of clean engine oil until you can see oil coming up the threads of the oil fill. Do not over fill.
6. Reinstall the oil dipstick and tighten it securely. Wipe clean any oil spillage and reinstall the oil access cover.

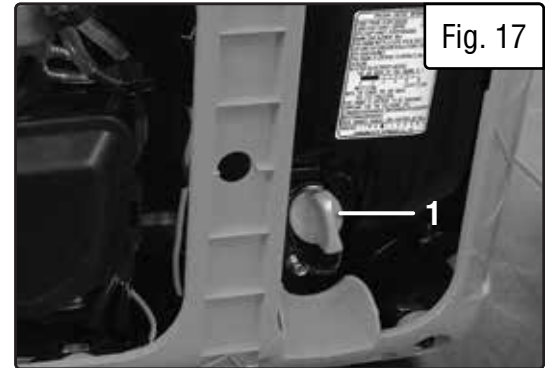

SPARK PLUG MAINTENANCE

Refer to Recommended Maintenance Schedule in Table 4 for maintaining the spark plug.

The spark plug is important for proper engine operation. Check the spark plug regularly to maintain proper engine operation. A good spark plug should be intact, free of deposits, and properly gapped.

To inspect or replace the spark plug:

1. Remove the spark plug access cover (Fig. 29 - 1).
2. Gently pull on the spark plug boot (Fig. 20 - 1) to remove it. Be careful not to tear any insulation or wire.
3. Insert the included spark plug wrench (Fig. 21) through the access cover hole to unscrew and then carefully remove the spark plug from the engine.

TIP: There is limited space for the wrench to turn. Use both rows of holes in the spark plug wrench to gain leverage to loosen the plug.

4. Visually inspect the spark plug. If it is cracked or chipped, or if the electrodes are worn or burned, discard it and replace with a new spark plug.

We recommend replacing with a **NGK CR5HS/Torch A5RTC** spark plug (part no. **56200-0806B**), available for purchase at **wenproducts.com**.

5. If re-using the spark plug, use a wire brush to clean any dirt from around the spark plug base, then re-gap the spark plug.
6. Measure the plug gap with a spark plug gap gauge. The gap should be **0.6 - 0.8mm (0.024 - 0.031 in.)** (Fig. 22). Carefully adjust the gap if necessary.
7. Screw the spark plug back into the spark plug hole using the spark plug wrench. Do not over-tighten spark plug. Recommended tightening of spark plug is **½ to ¾ of a turn** (9.0 - 11.0 ft-lb torque/12-15 Nm.) after spark plug gasket contacts spark plug hole.
8. Reinstall the spark plug boot, spark plug rubber cover, and service panel.

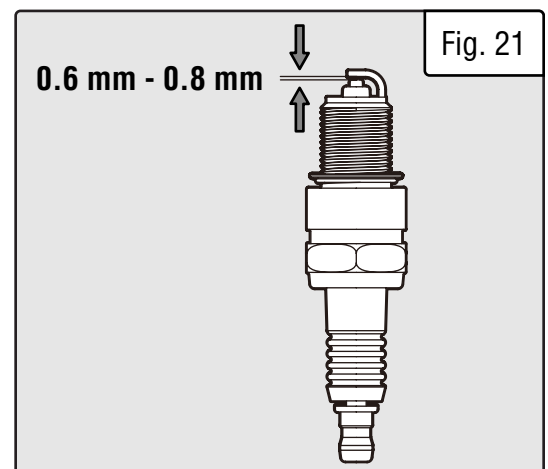
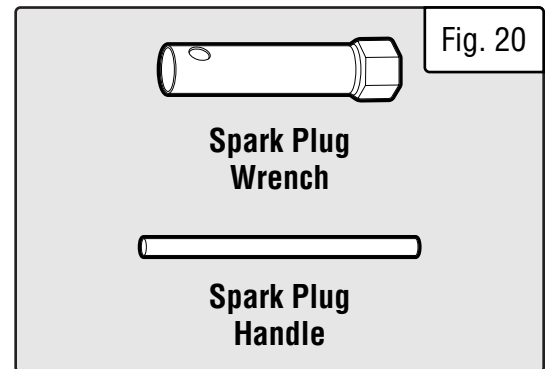
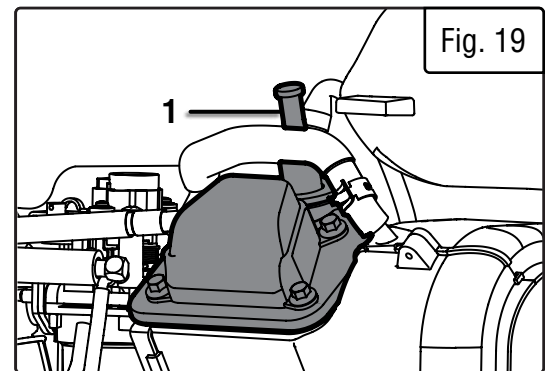
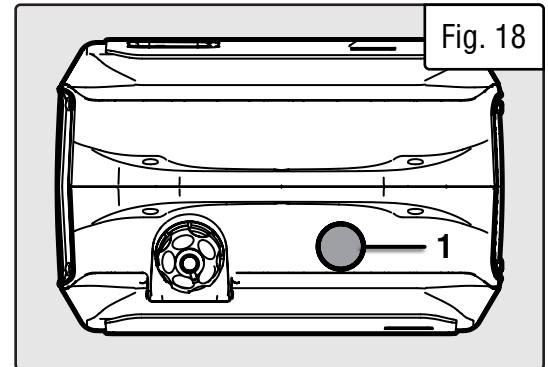

SPARK ARRESTOR MAINTENANCE

Inspect and clean the spark arrester every 100 hours of operation.

The spark arrester is located outside the muffler, which gets very hot during operation. Allow the engine to cool completely before servicing the spark arrester. To inspect and clean the spark arrester:

1. Remove the two bolts that secure the spark arrester (Fig. 23 - 1) to the muffler.
2. Remove the spark arrester screen.
3. Carefully clean and remove the carbon deposits from the spark arrester screen with a wire brush. Replace the spark arrester if it is damaged (replacement spark arrestors can be purchased from **wen-products.com** by searching the **part no. 56250i-0802.1**).
4. Reinstall the spark arrester in the muffler and secure it in place with the screw.

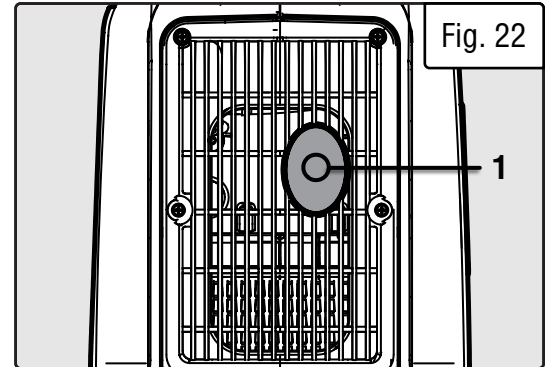

DRAINING THE FUEL TANK

Drain and clean the fuel tank each year, or before storing the generator for longer than two months.

To drain the fuel tank and carburetor:

1. Using a Phillips-head screwdriver, remove the two screws on the right side panel as shown in Fig. 15.
2. Locate the carburetor (Fig. 16 - 1) and the transparent drain tube (Fig. 16 - 2) from the carburetor that extends down through the bottom of the generator.
3. Prepare an approved gasoline-storage container and direct the end of the transparent tube into the container.
4. Use the screwdriver to loosen the drain screw (Fig. 16 - 3).
5. Remove the fuel cap and turn the FUEL SWITCH to the ON position.

NOTE: The draining process may take a few hours, depending on the amount of fuel in your gas tank.

6. Once fuel is completely drained, reinstall the fuel cap and turn the FUEL SWITCH to the OFF position. Tighten the drain screw with the screwdriver and reinstall the service panel.

6. Store emptied gasoline in a suitable place. **DO NOT** store flammable materials near the gasoline.

CAUTION: Store emptied gasoline in a suitable place. Never store fuel for more than 2 months.

TRANSPORTATION & STORAGE

TRANSPORTING THE GENERATOR

To prevent fuel spillage when transporting, be sure to perform the following:

1. Tighten the fuel cap and turn the vacuum relief valve to “OFF”.
2. Set the engine switch to “OFF”.
3. Drain the fuel tank if possible (see “DRAINING THE FUEL TANK”).
4. Keep the generator upright. Never place the generator on its side or upside down - doing so will make it difficult to start.

 **WARNING!** Avoid direct sunlight inside a vehicle. If generator is left in an enclosed vehicle for many hours, the high temp could cause the fuel to vaporize and result in a possible explosion.

STORING THE GENERATOR

Shut off the generator and allow the unit to cool to room temperature before storing it. NEVER place any type of storage cover on the generator while it is still hot. Do not obstruct any ventilation openings.

Follow the procedures below for properly storing your generator. We highly recommend running your generator once a month for 15 to 30 minutes. Plug in a small load in to ensure there is proper power output.

For Short Periods (30 to 60 Days):

- **Drain the carburetor.** Refer to, “Draining the Carburetor.”
- **Add fuel stabilizer:** Follow the suggested portions and instructions of your preferred stabilizer. Run the engine for 15 to 20 minutes, allowing the fuel stabilizer to mix with the gasoline and circulate through the carburetor, and then top off with fuel. Filling the fuel tank full reduces the amount of air in the tank and helps fight deterioration of fuel.

For Extended Periods (Over 60 Days):

- Drain the fuel tank and carburetor. Refer to, “Draining the Fuel Tank”. Never store generator with fuel in the tank for more than two months.
- Change the engine oil. Refer to, “Changing Oil”.

 **WARNING!** Store the generator upright in a cool and dry location, away from sources of heat, open flames, sparks or pilot lights.

PRODUCT DISPOSAL

Do not dispose of a used generator or parts with your household waste. This product contains electrical or electronic components that should be recycled. Please take this product to your local recycling facility for responsible disposal to minimize its environmental impact.

Do not dispose of used oil or fuel in the trash or down a drain. Please contact your local recycling center or auto garage to arrange proper oil/fuel disposal.



Please recycle the packaging and electronic components where facilities exist. Please contact your local auto garage or recycling facility to properly dispose of oil / fuel.

TROUBLESHOOTING GUIDE

⚠ WARNING! Stop using the generator immediately if any of the following problems occur or risk serious personal injury. If you have any questions, please contact our customer service at **1-847-429-9263**, M-F 8-5 CST or email us at **techsupport@wenproducts.com**.

PROBLEM	POSSIBLE CAUSE	SOLUTION
Engine will not start.	1. Fuel switch is set to OFF (0).	1. Turn fuel switch to ON.
	2. Oil is low.	2. Add oil.
	3. Engine is out of fuel.	3. Add fuel.
	4. Engine is filled with contaminated or old fuel.	4. Drain fuel in the tank and carburetor. Replace with fresh fuel.
	5. Spark plug is dirty or broken.	5. Clean or replace spark plug.
	6. Carburetor is air locked.	6. Turn the engine switch to OFF. Remove bolt from bottom of the carburetor. Take off the carburetor bowl to allow it to reset. Replace carburetor bowl and reinstall the bolt.
	7. Ghost in the generator.	7. Persuade ghost to leave. Consult Bill Murray if needed.
Engine runs but there is no electrical output.	1. Circuit breaker has been tripped due to overload.	1. Turn off and unplug all electrical devices. Wait 5 minutes, then press the circuit breaker to reset. Check the total wattage of the devices and reduce the load if it exceeds the capacity of the generator. Then plug the loads back in one by one.
	2. Bad connecting cords/wires.	2. Check the power cords and extension cords. Do not use if any cord is damaged. Replace damaged cords immediately.
	3. Bad electrical device connected to the generator.	3. Try connecting a different device.
Generator runs but does not support all electrical devices connected.	1. Generator is overloaded.	1. Turn off and unplug all electrical devices. Wait 5 minutes, then press the circuit breaker to reset. Reduce load as necessary, then plug devices back in one by one.
	2. Short circuit in one of the devices.	2. Try disconnecting any faulty or short-circuited electrical loads.
	3. Air filter is dirty.	3. Clean or replace the air filter element.
	4. Generator is in Eco-Mode and the load is too high.	4. Reduce the load or turn Eco-Mode off.
Engine is “Hunting” during Operation (Engine RPM is fluctuating).	1. The fuel isn’t running through the fuel valve. 2. The air filter is clogged. 3. The muffler or spark arrester is blocked 4. There is gunk in the carburetor preventing a consistent fuel/air mixture.	Turn off the generator and wait for it to cool down. Perform the following steps: 1. Check if the fuel is properly and consistently going through the fuel valve. 2. Check for any blockage in the air filter. Check and clean the air filter as necessary. 3. Check if the spark arrester is blocked. Clean with metal brush as necessary. 4. Use “gunk remover” spray on the carburetor jets.

WIRING DIAGRAM

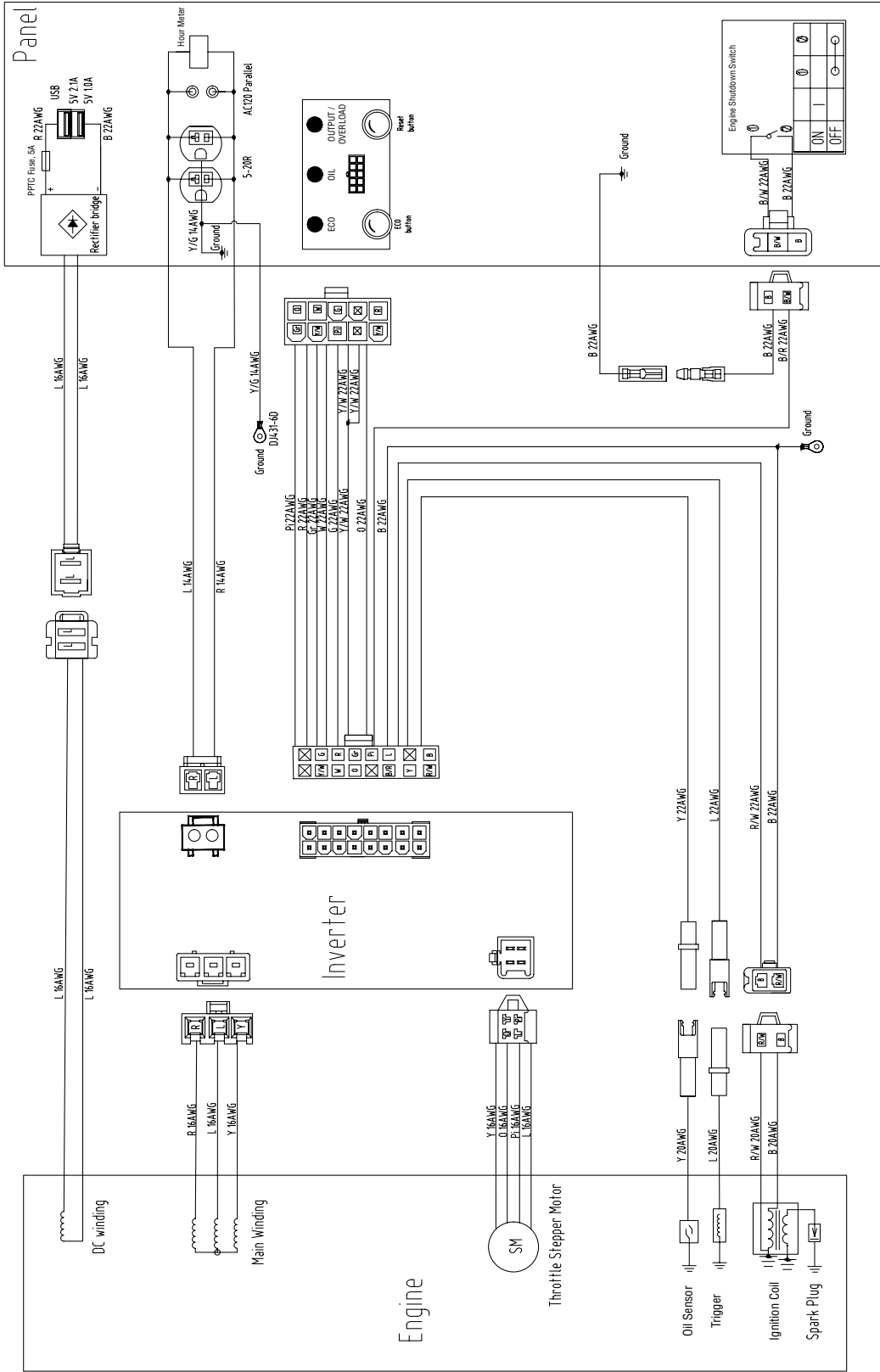

- Gr Grey
- B Black
- Br Brown
- G Green
- L Blue
- O Orange
- R Red
- W White
- Y Yellow
- P Purple
- B/W Black/White
- G/Y Green/Yellow
- R/W Red/White
- R/L Red/Blue
- G/B Green/Black
- Pi Pink

EXPLODED VIEW & PARTS LIST

NOTE: Replacement parts can be purchased from wenproducts.com, or by calling our customer service at **1-847-429-9263**, M-F 8-5 CST. Parts and accessories that wear down over the course of normal use are not covered by the three-year warranty. Not all parts may be available for purchase.

FIG. 1 - CRANKCASE

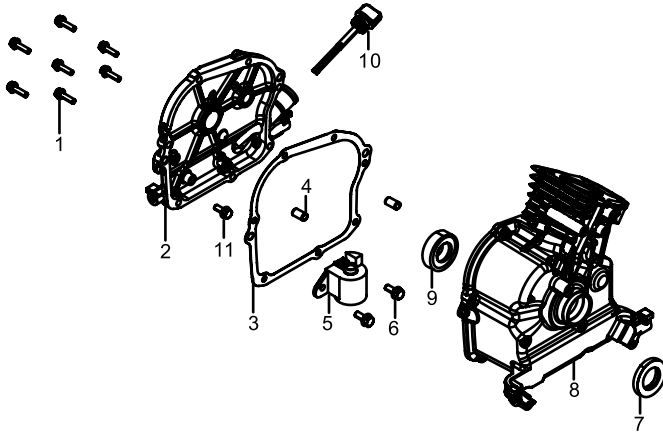

No.	Part No.	Description	Qty.
1	56250i-0101	Bolt, M6x22	7
2	56250i-0102	Crankcase Cover	1
3	56250i-0103	Crankcase Cover Gasket	1
4	56200-0803	Position Pin - Type A	2
5	56250i-0105	Engine Oil Sensor	1
6	56200-0629	Bolt, M6x14	2
7	56250i-0107	Oil Seal	1
8	56250i-0108	Crankcase Subassembly.	1
9	56200-0903	Deep Groove Ball Bearing - P53 6204	1
10	56250i-0110	Oil Dipstick Assembly	1
11	56250i-0111	Bolt, M6x10	1

FIG. 2 - CYLINDER HEAD AND COVER

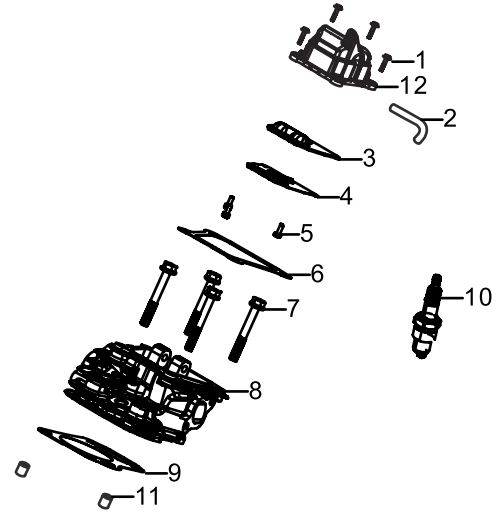

No.	Part No.	Description	Qty.
1	56310i-0209	Bolt, M6x16	4
2	56200-0814	Breather Tube	1
3	56250i-0203	Breather Plate	1
4	56250i-0204	Breather Plate Gasket	1
5	56200-0813	Phillips Pan Head Screw, M3x8	3
6	56250i-0206	Cylinder Head Cover Gasket	1
7	56200-0807	Cylinder Head Bolt, M6x50	4
8	56250i-0208	Cylinder Head Subassembly	1
9	56250i-0209	Cylinder Head Gasket	1
10	56200-0806B	Spark Plug, Torch A5RTC (NGK CR5HS)	1
11	56200-0803	Position Pin - Type A	2
12	56250i-0212	Cylinder Head Cover Assembly	1

EXPLODED VIEW & PARTS LIST

FIG. 3 - CRANKSHAFT AND CONNECTING ROD

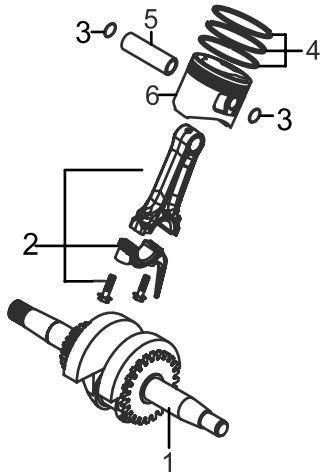
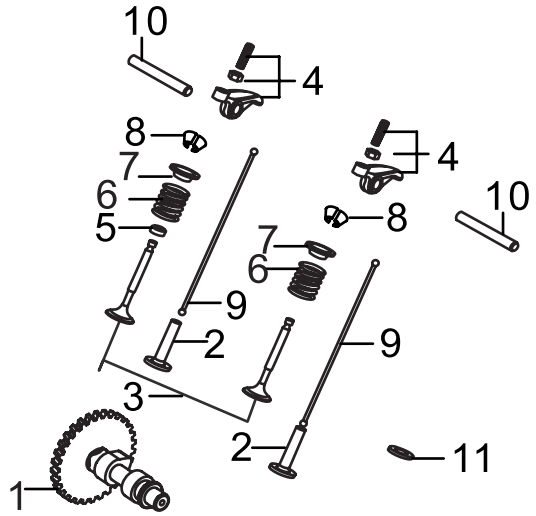

FIG. 4 - CAMSHAFT AND VALVES



No.	Part No.	Description	Qty.
1	56250i-0301	Crankshaft Assembly	1
2	56250i-0302	Connecting Rod	1
3	56200-1004	Piston Pin Clip	2
4	56250i-0304	Piston Ring Set	1
5	56200-1005	Piston Pin	1
6	56200-1003	Piston	1

No.	Part No.	Description	Qty.
1	56250i-0401	Camshaft Assembly	1
2	56200-1103	Valve Tappet	2
3	56250i-0403	Valves Set	1
4	56250i-0404	Valve Rocker Subassembly	2
5	56450i-0603	Seal Guide	1
6	56250i-0406	Valve Spring	2
7	56380i-0605	Valve Spring Seat	2
8	56310i-0606	Valve Lock Clamp	4
9	56200-1114	Valve Lifter Subassembly	2
10	56200-1112	Valve Rocker Shaft	1
11	56250i-0411	Valve Outer Spring Retainer	1

EXPLODED VIEW & PARTS LIST

FIG. 5 - RECOIL STARTER

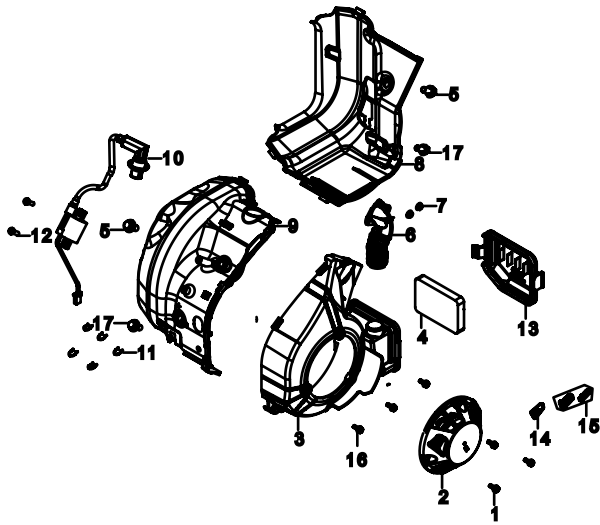
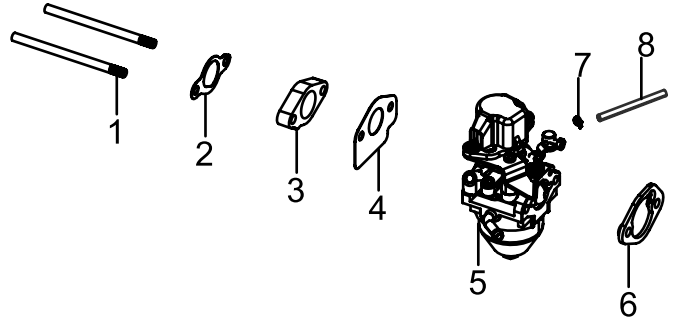

FIG. 6 - CARBURETOR ASSEMBLY



No.	Part No.	Description	Qty.
1	56310i-0209	Bolt, M6x16	3
2	56250i-0502	Recoil Starter Assembly	1
3	56250i-0503	Shroud	1
4	56250i-0504	Air Filter Element	1
5	56380i-0313	Bolt, M6x12	2
6	56250i-0506	Carburetor Intake Duct Assembly	1
7	56200-0506	Nut, M6	2
8	56250i-0508	Right Shroud	1
9	56250i-0509	Left Shroud	1
10	56250i-0510	Ignition Coil	1
11	56250i-0511	Clip	5
12	56250i-0512	Self-tapping Screw, ST4.8x19	2
13	56250i-0513	Air Filter Housing Cover	1
14	56250i-0514	Recoil Starter Guide Subassembly	1
15	56250i-0515	Recoil Starter Handle	1
16	56200-1202	Flanged Hex Bolt, M6x20	3
17	56250i-0517	Flanged Hex Bolt, M6x12	2

No.	Part No.	Description	Qty.
1	56250i-0601	Stud Bolt, M6x92	2
2	56250i-0602	Carburetor Insulator Gasket	1
3	56250i-0603	Carburetor Insulator Plate	1
4	56250i-0604	Carburetor Gasket	1
5	56250i-0605	Carburetor Assembly	1
6	56250i-0606	Air Filter Gasket	1
7	56380i-1435	Hose Clamp	1
8	56250i-0608	Fuel Line	1
N.P.	56250i-HA36	High-Altitude Kit, 3000 - 6000 ft	1
N.P.	56250i-HA68	High-Altitude Kit, 6000 - 8000 ft	1

EXPLODED VIEW & PARTS LIST

FIG. 7 - ALTERNATOR

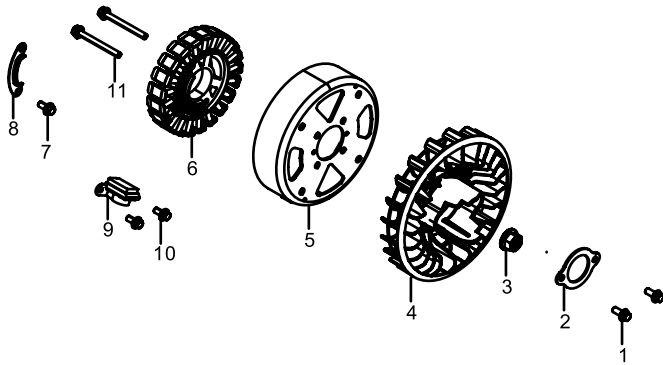

No.	Part No.	Description	Qty.
1	56200-0502	Flanged Hex Bolt, M6x14	2
2	56250i-0702	Impeller Gasket	1
3	56200-1601	Flywheel Nut, M12-1.25	1
4	56250i-0704	Impeller	1
5	56250i-0705	Rotor	1
6	56250i-0706	Stator	1
7	56380i-0313	Flanged Hex Bolt, M6x12	1
8	56250i-0708	Wiring Clamp	1
9	56250i-0709	Trigger	1
10	56250i-0710	Flanged Hex Bolt, M5x16	2
11	56200-0701	Flanged Hex Bolt, M6x30	2

FIG. 8 - MUFFLER

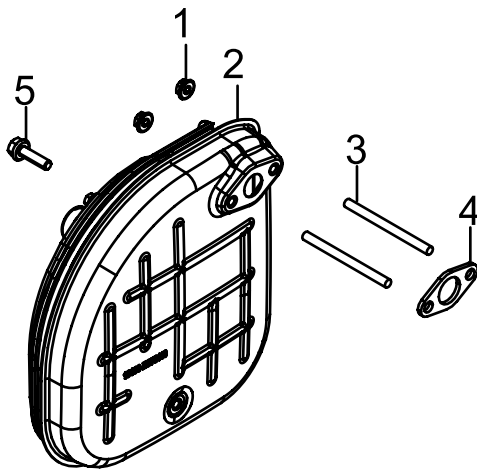

No.	Part No.	Description	Qty.
1	56250i-0801	Flanged Hex Nut, M6	2
2	56250i-0802	Muffler Assembly	1
N.P.	56250i-0802.1	Spark Arrestor	1
3	56250i-0803	Stud Bolt, M6x75	2
4	56200-1506	Muffler Gasket	1
5	56250i-0805	Flanged Hex Bolt, M6x60	1

FIG. 9 - FUEL TANK

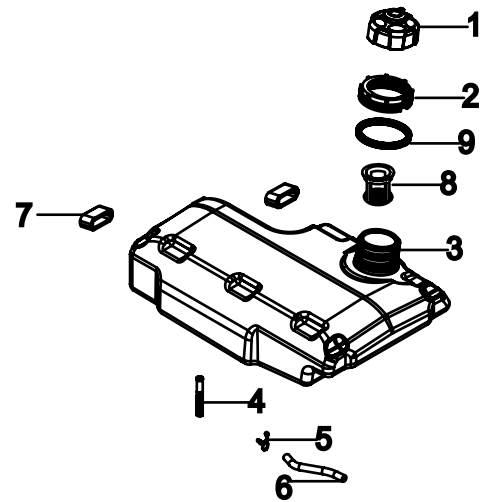

No.	Part No.	Description	Qty.
1	56250i-0901	Fuel Tank Cap	1
2	56250i-0902	Fuel Tank Nut, M54	1
3	56250i-0903	Fuel Tank	1
4	56200-0207	Fuel Line Filter	1
5	56250i-0905	Hose Clamp	1
6	56250i-0906	Fuel Line	1
7	56200-0206	Bushing	2
8	56250i-0908	Fuel Filter	1
9	56250i-0909	Sleeve, Filling Oil Hole Rubber	1

EXPLODED VIEW & PARTS LIST

FIG. 10 - CONTROL PANEL

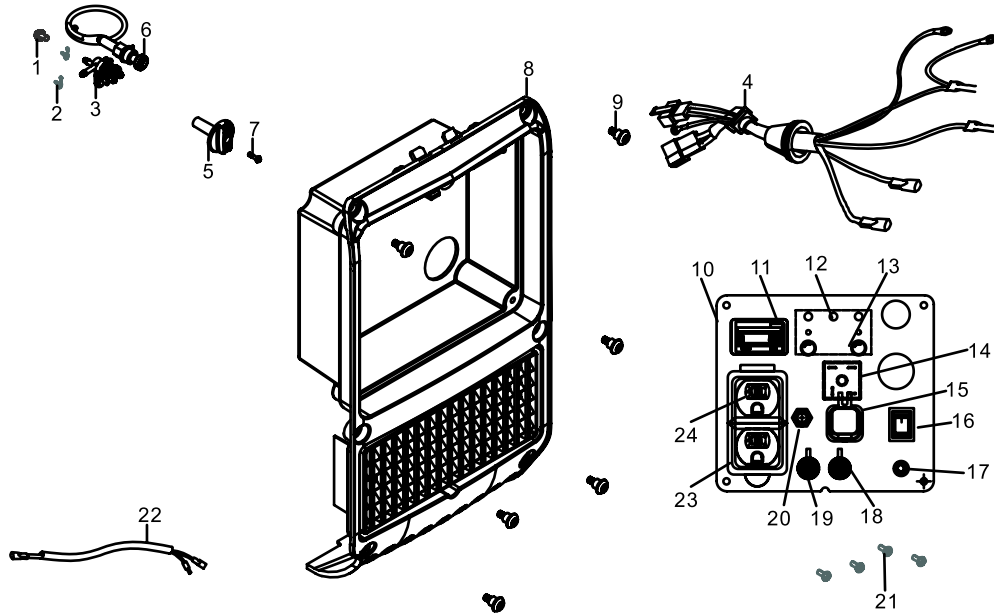

No.	Part No.	Description	Qty.	No.	Part No.	Description	Qty.
1	56250i-1001	Flanged Hex Bolt, M6x14	1	13	56250i-1013	Multimeter	1
2	56250i-1002	Hose Clamp	2	14	56380i-1432	Rectifier	1
3	56250i-1003	Fuel Valve	1	15	DF250iX-1124	USB Outlet	1
4	56250i-1004	Control Panel Wiring Harness	1	16	56380i-1431	Manual Shutdown Switch	1
5	56250i-1005	Knob	1	17	56250i-1017	Grounding Lug	1
6	56250i-1006	Choke Cable	1	18	56380i-1423	Parallel Port, Black	1
7	56200-0514	Phillips Pan Head Screw, M4x16	1	19	56380i-1424	Parallel Port, Red	1
8	56250i-1008	Panel Seat	1	20	56250i-1020	AC Breaker, 20A	1
9	56250i-1009	Hex Step Bolt, M5x14	6	21	56250i-1021	Phillips Pan Head Bolt, M5x12	4
10	56250i-1010ASM	Control Panel Subassembly	1	22	56250i-1022	Grounding Wire	1
11	56250i-1011	Hour Meter	1	23	56250i-1023	Receptacle Cover	1
12	DF250iX-1143	Indicator Mounting Base	3	24	56380i-1421	NEMA 5-20R Duplex AC Receptacle	1

EXPLODED VIEW & PARTS LIST

FIG. 11 - HOUSING

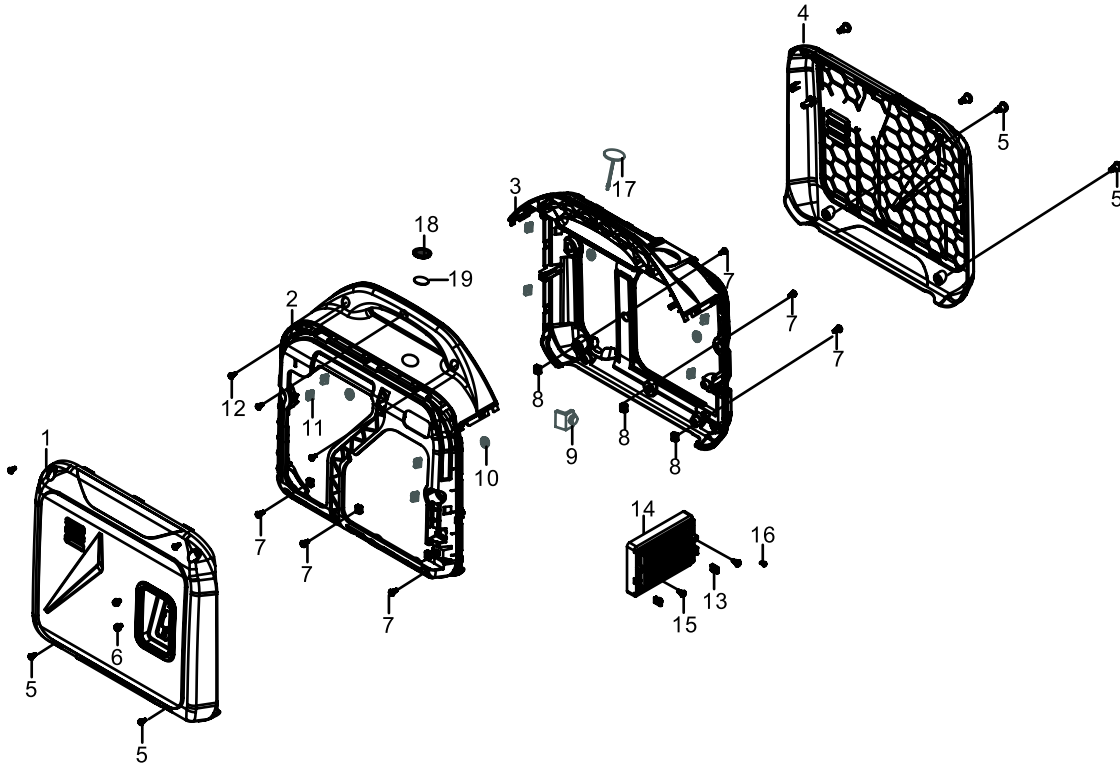

No.	Part No.	Description	Qty.	No.	Part No.	Description	Qty.
1	56250i-1101	Left Side Panel	1	9	56250i-1109	Engine Cushion 1	1
2	56250i-1102	Left Housing	1	10	56200-0515	Fuel Line Bushing	4
3	56250i-1103	Right Housing	1	11	56250i-1111	Clip Nut, M6	8
4	56250i-1104	Right Side Panel	1	12	56250i-1112	Hex Step Bolt, M5x14	3
5	56250i-1105	Phillips Captive Pan-Head Screw, M5x4	4	13	56250i-1113	Clip Nut, M5	2
6	56200-0302	Phillips Pan Head Screw, Spring Washer And Flat Washer Assembly, M5x12	2	14	56250i-1114	Inverter	1
7	56380I-1607	Hex Step Bolt, M6x20	6	15	56250i-1115	Hex Step Bolt, M5x14	2
8	56200-0408	Square Nut - Grade C	6	16	56250i-1116	Phillips Pan Head Screw, M6x5	1
				17	56200-0414	Spark Plug Access Cover	1
				18	56200-0412	Rubber Cover	1
				19	56200-0413	Fuel Gauge Cover	1

EXPLODED VIEW & PARTS LIST

FIG. 12. BOTTOM PLATE

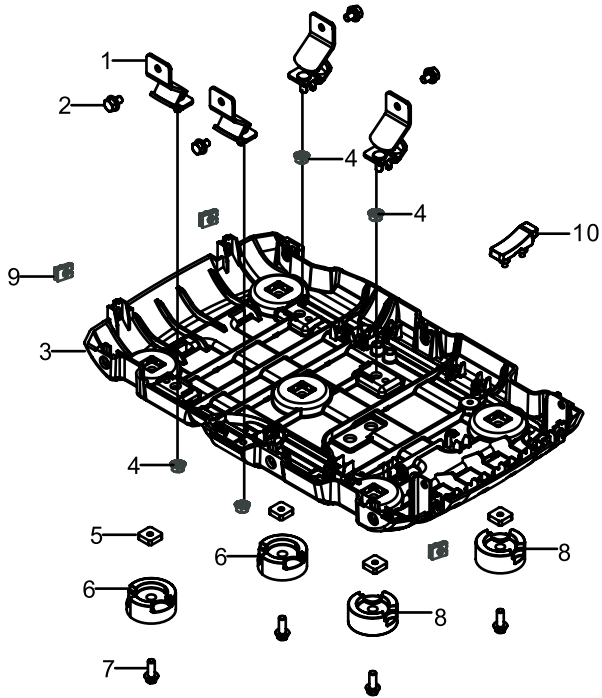

No.	Part No.	Description	Qty.
1	56200-0507	Engine Frame Cushion M6x10.5	4
2	56250i-1202	Flanged Hex Bolt, M6x12	4
3	56250i-1203	Bottom Plate Subassembly	1
4	56250i-1204	Flanged Hex Nut, M6	4
5	56200-0408	Square Nut - Grade C	4
6	56200-0504	Foot 1	2
7	56250i-1207	Flanged Hex Bolt, M6x14	4
8	56200-0503	Foot 2	2
9	56250i-1209	Clip Nut	4
10	56200-0510	Engine Cushion 2	1

FIG. 13. MUFFLER COVER

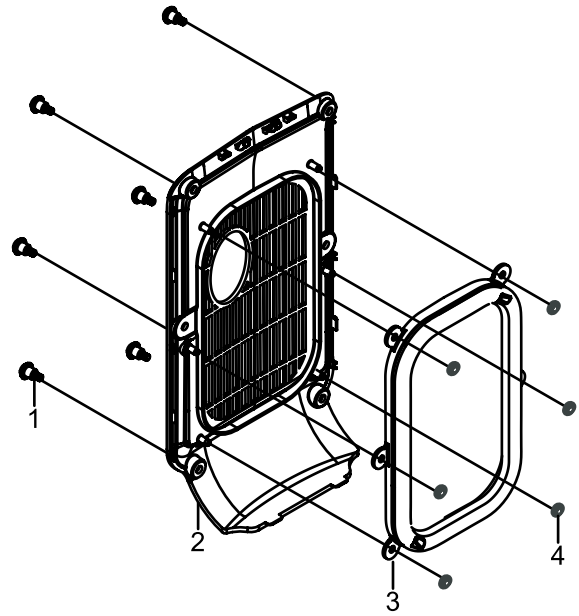

No.	Part No.	Description	Qty.
1	56250i-1301	Hex Step Bolt, M5x14	6
2	56250i-1302	Muffler Cover Panel	1
3	56250i-1303	Muffler Cover Seal	1
4	56200-0427B	Spring Clamp	6

WARRANTY STATEMENT

WEN Products is committed to building tools that are dependable for years. Our warranties are consistent with this commitment and our dedication to quality.

LIMITED WARRANTY OF WEN PRODUCTS FOR HOME USE

GREAT LAKES TECHNOLOGIES, LLC (“Seller”) warrants to the original purchaser only, that this WEN consumer product will be free from defects in material or workmanship during personal use for a period of three (3) years from date of purchase or 500 hours of use; whichever comes first. Ninety days for all WEN products if the tool is used for professional or commercial use. Purchaser has 30 days from the date of purchase to report missing or damaged parts. Parts and labor are covered for one (1) year under this limited warranty; parts only are covered for three (3) years under this limited warranty.

SELLER’S SOLE OBLIGATION AND YOUR EXCLUSIVE REMEDY under this Limited Warranty and, to the extent permitted by law, any warranty or condition implied by law, shall be the replacement of parts, without charge, which are defective in material or workmanship and which have not been subjected to misuse, alteration, careless handling, misrepair, abuse, neglect, normal wear and tear, improper maintenance, improper storage, incorrect lubricants / fuels, or other conditions adversely affecting the Product or the component of the Product, whether by accident or intentionally, by persons other than Seller. To make a claim under this Limited Warranty, you must make sure to keep a copy of your proof of purchase that clearly defines the Date of Purchase (month and year) and the Place of Purchase. Place of Purchase must be a direct vendor of Great Lakes Technologies, LLC. Purchasing through third party vendors, including but not limited to garage sales, pawn shops, resale shops, or any other secondhand merchant, voids the warranty included with this product. Contact techsupport@wenproducts.com or 1-847-429-9263 with the following information to make arrangements: your shipping address, phone number, serial number, required part numbers, and proof of purchase. Damaged or defective parts and products may need to be sent to WEN before the replacements can be shipped out.

Upon the confirmation of a WEN representative, your product may qualify for repairs and service work. When returning a product for warranty service, the shipping charges must be prepaid by the purchaser. The product must be shipped in its original container (or an equivalent), properly packed to withstand the hazards of shipment. The product must be fully insured with a copy of the proof of purchase enclosed. There must also be a description of the problem in order to help our repairs department diagnose and fix the issue. Repairs will be made and the product will be returned and shipped back to the purchaser at no charge for addresses within the contiguous United States.

THIS LIMITED WARRANTY DOES NOT APPLY TO ITEMS THAT WEAR OUT FROM REGULAR USAGE OVER TIME, INCLUDING FILTERS, SPARK PLUGS, VOLTAGE REGULATORS, BRUSHES, GASKETS, O-RINGS, WHEEL KITS, BATTERIES, RECOIL STARTERS, HIGH PRESSURE HOSES, SPRAY GUNS, ETC. ANY IMPLIED WARRANTIES SHALL BE LIMITED IN DURATION TO THREE (3) YEARS FROM DATE OF PURCHASE. SOME STATES IN THE U.S. AND SOME CANADIAN PROVINCES DO NOT ALLOW LIMITATIONS ON HOW LONG AN IMPLIED WARRANTY LASTS, SO THE ABOVE LIMITATION MAY NOT APPLY TO YOU.

IN NO EVENT SHALL SELLER BE LIABLE FOR ANY INCIDENTAL OR CONSEQUENTIAL DAMAGES (INCLUDING BUT NOT LIMITED TO LIABILITY FOR LOSS OF PROFITS) ARISING FROM THE SALE OR USE OF THIS PRODUCT. SOME STATES IN THE U.S. AND SOME CANADIAN PROVINCES DO NOT ALLOW THE EXCLUSION OR LIMITATION OF INCIDENTAL OR CONSEQUENTIAL DAMAGES, SO THE ABOVE LIMITATION OR EXCLUSION MAY NOT APPLY TO YOU.

THIS LIMITED WARRANTY GIVES YOU SPECIFIC LEGAL RIGHTS, AND YOU MAY ALSO HAVE OTHER RIGHTS WHICH VARY FROM STATE TO STATE IN THE U.S., PROVINCE TO PROVINCE IN CANADA AND FROM COUNTRY TO COUNTRY.

THIS LIMITED WARRANTY APPLIES ONLY TO ITEMS SOLD WITHIN THE UNITED STATES OF AMERICA, CANADA AND THE COMMONWEALTH OF PUERTO RICO. FOR WARRANTY COVERAGE WITHIN OTHER COUNTRIES, CONTACT THE WEN CUSTOMER SUPPORT LINE. FOR WARRANTY PARTS OR PRODUCTS REPAIRED UNDER WARRANTY SHIPPING TO ADDRESSES OUTSIDE OF THE CONTIGUOUS UNITED STATES, ADDITIONAL SHIPPING CHARGES MAY APPLY.

**THANKS FOR
REMEMBERING**

